



vol. 16 / 2023



The 7th International Conference on Science Technology

organized by
Faculty of Social Science and
Law Universitas Negeri Manado and
Consortium of International Conference
on Science and Technology

The Innovation Breakthrough in Digital and Disruptive Era

A Mini Review: Preliminary Study of Bio-Medical Physics on Development of FRRS to Reduce Pain After Heavy Activities

Primasari Cahya Wardhani^{1*}, Nur Aini Fauziyah¹, Pardi Sampe Tola¹, and Zakiyah Dania Billah²

¹Department of Physics, Faculty of Engineering and Science, UPN Veteran Jawa Timur, Surabaya, Indonesia

²Department of Information System, Faculty of Technology and Informatics, Universitas Dinamika, Surabaya, Indonesia

Abstract. Reflexology on the feet is a traditional Chinese medicine (TCM) therapy method. Specifications that must be considered in the manufacture of electrostimulators for acupuncture therapy are waveform, intensity, frequency, and duration of therapy. Scientific studies have confirmed that TCM FB can promote microcirculation, improve skin permeability, and boost drug absorption. Based on data from research collected in the last five years, the method used for foot reflexology is TENS, FES, FNS, and the manufacture of reflexology cotton sandals. By looking at these significant results of the usage of foot stimulator, but it has not been supported by the development of a comprehensive foot reflexology device. Thus, the development of the FRRS device has the potential to become a non-invasive and non-pharmacological therapy device with several advantages in its usage using magnetic electrodes (magnetic plate electrodes), which are very effective at directing the flow of electrical energy to the body through the soles of the feet.

Keywords: foot relaxation-reflection, electrostimulator, foot therapy, pain

* Corresponding author: primasri.cahya.fisika@upnjatim.ac.id

1 Introduction

A foot stimulator is a method of providing stimulation to acupuncture points on the feet. This therapeutic method is an alternative therapy that can be used in health therapies' [1]. The therapy utilizes the electric current given to the feet as a method of reflection and relaxation. In therapy using a stimulator given to the feet, acupuncture treatment methods can be carried out by giving stimulation in the form of electrical energy through acupuncture meridian points [2-4]. Specifications that must be considered in the manufacture of electrostimulators for acupuncture therapy are waveform, intensity, frequency, and duration of therapy. In addition, it is also necessary to pay attention to the electrodes as conductors of electrical energy that is distributed to the body [5,6].

In the body, the use of an electrostimulator is closely related to the application of physics, namely the existence of electrical conduction and dielectric polarization. Electrodes installed in the human body, when the stimulator is administered, the molecules in the body, which are mostly liquids, will cause a polarization process so that the electric charge in the cell will experience a shift until there is a separation of positive and negative charges which causes a double electric pole and produces a polarization potential [7]. The process of providing electrostimulation to the body is as illustrated in Fig.1 [8].

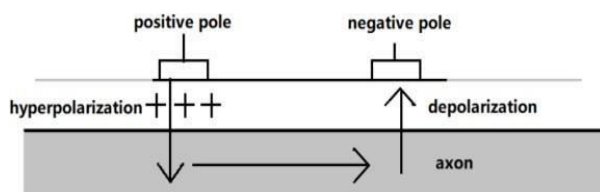

Fig 1. Electrostimulation process (source: [8])

Several previous studies stated that reflexology is a non- invasive and non-pharmacological therapy [9,10]. Reflexology is an effective therapy that can be used to relax the body and also has other benefits for the body [11]. In addition, it can reduce muscle stiffness, reduce fatigue, reduce pain that occurs in postpartum patients, Pre Menstrual Syndrom, and also chemotherapy patients [12,13]. Moreover, foot reflexology can also reduce blood pressure in hypertensive patients [14,15].

Reflexology on the feet is a traditional Chinese medicine (TCM) therapy method. TCM foot baths (FB) and acupoint massages (AM) are two essential components of traditional Chinese medicine's (TCM) external treatments [15]. These practices have been used in China for centuries, and studies have shown that TCM FB may boost skin permeability, improve microcirculation, and elevate drug absorption. In the meantime, AM can improve microcirculation, reduce inflammation, eliminate free radical production, and keep the dynamic balance of it [16-18]. In the case of diabetes mellitus (DM), TCM treatment has several methods, some of which are depicted in Fig.2.

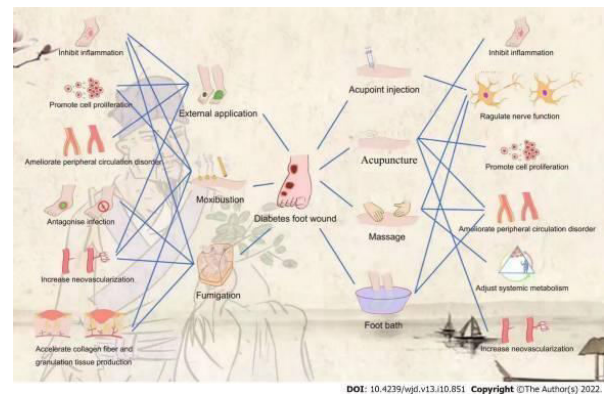

Fig 2. TCM treatment for Diabetes Mellitus (DM)

(Source: [16])

Providing reflexion on the body indicates that the energy that moves in giving a massage can repair and open closed channels to become open because of the energy given to body. Thus, the provision of electronic stimulation to the soles of the feet is expected to have a positive effect on medical therapy [19].

In previous research, providing thermal stimulation to the soles of the feet combined with other sensory stimuli can cause relaxation. In the study by (FUJIWARA et al., 2022) [20]. The study's findings were said to be able to identify the relaxation-inducing properties of thermal stimulation combined with focused stimuli on other sensory organs, as well as variations in the latency and duration of physiological responses to every stimulus. Thermal stimulation significantly impacts sensations of relaxation, although it is undetermined to what extent multisensory integration enhances this effect [20].

The current research is making a foot reflection-relaxation stimulator (FRRS) device, or known as foot stimulator. The working principle of the foot stimulator is to provide low-power electrical energy stimulation through three channels at once, namely not only based on the flow of electrical energy through acupuncture points and meridians, stimulation of electrical energy through reflex points on the soles of the feet, and stimulation of electrical energy through nerves and muscles.

1.1 The effect of giving foot reflexion therapy

Reflexology on the feet can be done in several ways, including doing reflexology on the feet, giving electrical stimulation to the feet, soaking the feet with hydrotherapy, and electro-acupuncture on the feet. These methods have the same goal: to stimulate the feet to relax the muscles in the legs [21]. The human foot has many acupuncture points connecting to other organs of the human body [22]. In traditional foot reflexology therapy, hand massage is still used for this reflexology therapy, whereas in modern methods or using an automation system, an electrical stimulator is used [16]. When using the electrical stimulator, paying attention to the impedance tolerance limit on human skin, which is 1-kilo ohm is necessary [16,23].

Transcutaneous Electrical Nerve Stimulation (TENS) was used to lessen the side effects of chemotherapy, such as nausea, cachexia, insomnia, and pain, in patients with advanced cancer. It can aid palliative care, even though it cannot be used as a substitute for opioids and other pharmaceutical treatments [24]. TENS is less complicated, safer, reproducible, and more suitable for long-term home patients who are unable to take medications orally for self-management than the conventional acupuncture point treatment, making it worthy of clinical promotion. According to numerous research [6,24], TENS is effective in treating cancer patients' physical symptoms such as constipation, exhaustion, nausea, and vomiting during palliative care in addition to relieving their pain.

In traditional foot massage therapy, previous studies have shown that providing therapeutic massage time in the range of 20 – 30 minutes can reduce muscle stiffness significantly, and a lower fatigue index was observed in the massage trial ($p = 0.04$; mean (SD) fatigue index 30.2 (4.1)% v 34.2 (3.3)%) [25,26].



Fig 3. Foot Reflexology (source: [19])

The mean \pm standard deviation of fatigue in the three phases of evaluation in the experimental group was 5.91 ± 0.81 , 4.80 ± 1.19 , 4.55 ± 1.57 and in the control, group was 5.95 ± 0.97 , 6.06 ± 1.13 and 5.79 ± 1.33 , respectively. After the intervention, the means of the fatigue scores differed significantly from one another, in both groups ($p < 0.001$). This approach, which is non-pharmacological, simple to apply, and indicated to alleviate fatigue in elderly diabetic patients, demonstrates the benefits of warm foot bathing [12].

The patients receiving hemodialysis were worn exhausted. A warm water footbath can help people undergoing hemodialysis feel less worn out. In addition, previous research has shown that soaking your feet in warm water can reduce muscle fatigue and improve blood flow. According to science, warm water affects blood vessels because it has physiological effects on the body [27]. Warm water stabilizes blood flow and heart rate while facilitating smooth blood circulation. The muscles and ligaments that affect the body's joints will strengthen while submerged in warm water. A natural, affordable, secure, and cozy therapy for the elderly combines warm water therapy,

progressive muscle relaxation, and foot soaks. Simple and convenient equipment and supplies are required [27,28].

1.2 The five years development of stimulator on foot reflexology, relaxation, and rehabilitation

In the world of healthcare professions, electrical stimulation therapy can function as an initial diagnosis and therapy tool and can even improve work functions in the human body [29]. In its development, Functional electrical stimulation (FES) and functional neurostimulation (FNS) are still used today, and they can function to server the earlier three purposes. Several studies have stated that the development of the use of electrical stimulators on the feet as a tool for reflexology, relaxation, and also rehabilitation uses electric pulses at currents in the range of 0 – 100 mA and uses a low frequency of 17 – 40 Hz, with a pulse width of 100 – 300 μ s [8]. Another study mentions the design of a foot therapy device using a microcontroller, a GSR sensor to read skin resistance, and a wave generator. It states that stimulation at a voltage of 25 – 50 V has a greater current than at a voltage of less than 25 V, where the resistance measured on the finger under dry skin conditions is measured at 475 Ω , and on wet skin, the resistance value tends to increase by 555 Ω [30]. In further development, Chandrasekar et al., 2019 [19], they developed an electronic design of cotton sandals for foot reflexology. This design uses a power supply, rectifier, and IC 7805 to generate a supply voltage of 5V – \pm 5V regulator functions to operate the microcontroller and the relay. The 230V operated electric air pump is used to suck and pump atmospheric air. The pump output is connected to the solenoid valve inlet. A microcontroller controls solenoid relays and valves. A solenoid valve is connected to a hose to circulate air to an airbag that is inserted into the cotton house slippers. The flow system of the circuit is illustrated in fig 4.

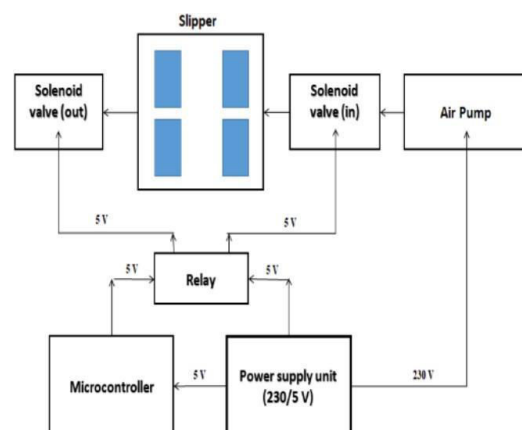

Fig 4. The flowchart system of circuit board system (source [19])

The reflexology time took less than 30 minutes. The left foot received the treatment first, followed by the right foot (15 minutes each). As a result, the microcontroller is set up to activate each airbag in turn

for 15 minutes in the left sandals, followed by 15 minutes of operation in the right sandals. The relay first runs in NORMALLY ON mode. As a result, the inlet regulating solenoid valve opens for 5 seconds, extending the projection during that time. The relay then controls the outlet-connected solenoid valve for three seconds while operating in NORMALLY OFF mode. [8,19,24].

2 Method

In this study, the design of the FRRS device is shown in Figure 5. The FRRS block diagram has a frequency control panel, timer, and also time display that can make it easier for users or therapists to use FRRS devices.

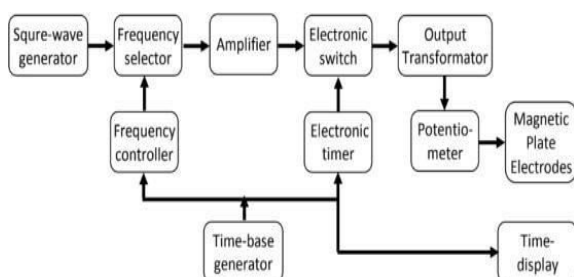

Fig 5. Diagram Block of FRRS system (source: data of research)

3 Result and Discussion

According to the definition, Pain in the body arises from direct or potential damage or feelings of discomfort and emotional experience due to injury [23,31]. When drugs are used for pain relief, side effects such as indigestion, ulcers, gastrointestinal bleeding, and duodenal perforation can occur. Therefore, physiotherapy and non-drug therapy, such as electrotherapy, thermal therapy, and cryotherapy (CR), are used to reduce or eliminate side effects [3].

Therapeutic methods to relieve pain non-pharmacologically and non-invasively can be done by applying different temperatures to the skin. They can use compress therapy with hot water or cold water. This can be applied to acute and sub-acute patients. Providing heat treatment can also be a short way of recovery for athletes who have finished training, competing, or other strenuous activities. Giving heat treatment therapy can open and improve blood flow [32]. However, this conventional foot bath therapy method is less efficient because it requires a large bathtub, limited water heating control, and a relatively longer therapy preparation time. In developments in the world of foot reflexology that still utilizes the TCM method [2,3], it shows that reflexology on foot acupuncture points significantly reduces aches and pains in patients with high or strenuous activities. In research that has been done, methods of foot soaking, giving electrostimulation, foot massage, and acupuncture can reduce various kinds of diseases in the body and can improve blood flow in the human body [17]. By looking at these

significant results, it has not been supported by the development of a comprehensive foot reflexology tool. Based on data from research collected in the last five years, the methods used for foot reflexology are TENS, FES, FNS, and the manufacture of reflexology cotton sandals. The study shows that several aspects affect the effectiveness of therapy, namely pulse width, duration of therapy, intensity, and frequency of pulses given to the body.

According to the results of the data review analysis, it can be concluded that relaxation of the feet using thermal variations can also positively affect body health. Thus, this study developed the Foot Reflection-Relaxation Stimulator (FRRS) to provide better therapeutic effectiveness. In this study, the study of physics related to the performance of FRRS devices has several advantages. This is because the FRRS method utilizes a combination of electrical and magnetic energy, which can stimulate energy flowing from the surface of the soles of the feet through acupuncture points and meridians, reflex points and nerve, and muscle pathways non-invasively.

The magnetic field directs the flow of electrical energy on the surface of the soles so that it can reach the intended stimulation points. Thus, this therapeutic method no longer requires needle electrodes (invasive method). The electric pulse generated by the FRRS device has a unique characteristic, namely a spike-biphase pulse that has optimal therapeutic effectiveness. The shape of the spike-biphase pulse can be described graphically, as shown in Fig 6.

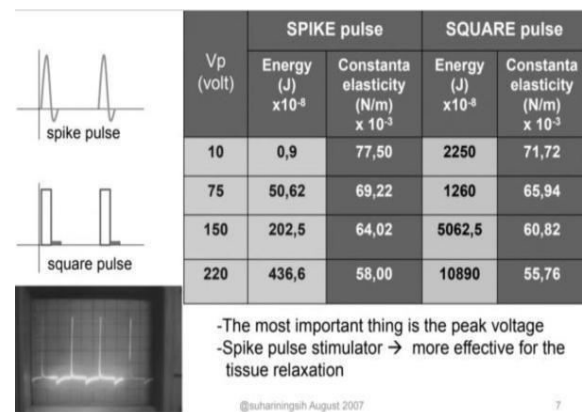

Fig 6. The shape of the spike-biphase pulse (Source: [7])

Based on the voltage versus time curve of the spike-biphase pulse in Figure 6, it appears that this spike-biphase pulse has a high amplitude and a narrow pulse duration. The narrowness of the pulse duration mathematically impacts the ratio between the effective voltage to the peak voltage (amplitude), which has a very small value, so even though the peak voltage value is high, the effective voltage value is relatively small. This allows higher amplitude signals to be provided with minimal flavor. The high amplitude of the spike pulse causes this FRRS stimulation to be impulsive, so it is very effective in causing a flow of electrons and ions on the path it is traversing.

4 Conclusion

In developments in the world of foot reflexology that still utilizes the TCM method, it shows that reflexology on foot acupuncture points significantly reduces aches and pains in patients with high or strenuous activities. In research that has been done, methods of foot soaking, giving electrostimulation, foot massage, and acupuncture can reduce various kinds of diseases in the body and can improve blood flow in the human body. By looking at these significant results, it has not been supported by the development of a comprehensive foot reflexology device. Based on data from research collected in the last five years, the method used for foot reflexology is TENS, FES, FNS, and the manufacture of reflexology cotton sandals. Based on the research, it is written that several aspects affect the effectiveness of therapy, namely pulse width, duration of therapy, intensity, temperature, and also the frequency of pulses given to the body. Thus, the development of the FRRS device has the potential to become a non-invasive and non-pharmacological therapy device with several advantages in its usage using magnetic electrodes (magnetic plate electrodes), which are very effective at directing the flow of electrical energy to the body through the soles of the feet. However, it is necessary to carry out further studies to see and test the performance of FRRS on the body's response and the stability of the device's performance.

Acknowledgment

The authors would like to thank LPPM UPN "VETERAN" JAWA TIMUR through Riset Dasar (Nomor: SPP/6/UN.63.8/LTIVI2023) that is funding on 2023 for the financial support in this research. Furthermore, The authors also thank to all of team members for the help so that it can be granted.

References

- [1] I. Levy *et al.*, *Complement Ther Clin Pract* **38**, (2020).
- [2] A. S. Adly *et al.*, *Lasers Med Sci* **32**, 1097 (2017).
- [3] S. El-Gendy, *International Journal of Physiotherapy* **2**, (2015).
- [4] R. Peron, É. P. Rampazo, and R. E. Liebano, *Trials* **23**, (2022).
- [5] A. J. Hayes and J. Melrose, *Adv Ther (Weinh)* **3**, 2000151 (2020).
- [6] D. C. James, M. C. Solan, and K. N. Mileva, *J Foot Ankle Res* **11**, (2018).
- [7] S. Suharningsih, (2020).
- [8] J. Wang and Y. Zhang, in *J Phys Conf Ser* (IOP Publishing Ltd, 2021).
- [9] A. Ketenci and M. Zure, *Turkish Journal of Physical Medicine and Rehabilitation* **67**, 1 (2021).
- [10] W. Mostafa Ahmed Gamel and M. Mohamed Tosson, *Effect of Foot Reflexology on Relieving Labor Pain and Enhancing Satisfaction among Parturient Women* (2022).
- [11] E. Bakir, S. S. Baglama, and S. Gursoy, *Complement Ther Clin Pract* **31**, 315 (2018).
- [12] F. Farnia, S. Mokhtari, and M. Rahmanian, *Elderly Health Journal* (2019).
- [13] L. Zengin and R. Aylaz, *Eur J Cancer Care (Engl)* **28**, (2019).
- [14] N. Rejeh *et al.*, *Nurs Res Pract* **2020**, (2020).
- [15] S. Suryaningsih, R. Tasalim, and S. Rahman, *Journal of Advances in Medicine and Pharmaceutical Sciences (JAMAPS)* **1**, 44 (2022).
- [16] Q. Fu *et al.*, *Diabetes/Metabolism Research and Reviews* **36**, (2020).
- [17] C. Lu *et al.*, *Chinese General Practice* **25**, 4106 (2022).
- [18] S. R. vakilinia *et al.*, *Complement Ther Med* **49**, 102325 (2020).
- [19] Chandrasekar S, *Asian Journal of Convergence in Technology V Issue I*, (n.d.).
- [20] S. FUJIWARA *et al.*, *International Journal of Affective Engineering* **21**, 43 (2022).
- [21] O. Prince-hector Chimeremeze, *MULTIMODAL INTERACTION FRAMEWORK FOR VIRTUAL REALITY FOOT REFLEXOLOGY STRESS THERAPY* (n.d.).
- [22] K. J. Baljon *et al.*, *BMJ Open* **10**, (2020).
- [23] D. P. Artioli, A. L. de F. Tavares, and G. R. F. Bertolini, *Brazilian Journal Of Pain* (2021).
- [24] J. Ying *et al.*, *Evidence-Based Complementary and Alternative Medicine* **2023**, 5383821 (2023).
- [25] A. Robertson, J. M. Watt, and S. D. R. Galloway, *Br J Sports Med* **38**, 173 (2004).
- [26] A. Samarehfekri *et al.*, *Evidence-based Complementary and Alternative Medicine* **2020**, (2020).

- [27] H. F. Shafeik, S. H. Abdelaziz, and S. I. ElSharkawy, *International Journal of Nursing* **08**, 26 (2018).
- [28] S. Fadlilah *et al.*, *Soak Feet with Warm Water and Progressive Muscle Relaxation Therapy on Blood Pressure in Hypertension Elderly* (n.d.).
- [29] D N Rushton, *Physiol Meas* **18**, 241 (1997).
- [30] E. Loniza, K. Chairunnisa, and I. Wulandari, in *2022 2nd International Conference on Electronic and Electrical Engineering and Intelligent System (ICE3IS)* (2022), pp. 355–359.
- [31] T. Aboud and N. M. Schuster, *Current Treatment Options in Neurology* **21**, (2019).
- [32] F. Farnia, S. Mokhtari, and M. Rahmanian, *Elderly Health Journal* (2019).