



vol. 17 / 2023



The 7th International Conference on Science Technology

organized by
Faculty of Social Science and
Law Universitas Negeri Manado and
Consortium of International Conference
on Science and Technology

The Innovation Breakthrough in Digital and Disruptive Era

Solid Biomass Uses A Mixture Of Agricultural Waste As An Alternative Fuel

Rullie Annisa^{1*}, Ibnu Irawan², Rifky Yusron³ and Yusril Arifiyanto⁴

^{1,4}Department of Industrial Engineering, Faculty of Engineering, Universitas Trunojoyo Madura, 69162 Bangkalan, Indonesia

^{2,3}Department of Mechanical Engineering, Faculty of Engineering, Universitas Trunojoyo Madura, 69162 Bangkalan, Indonesia

Abstract. Biomass is one of the agricultural waste that can be used as an alternative fuel substitute that is converted first into a briquette, the goal is to become an environmentally friendly fuel. Corn cobs and rice straw are one of the most common types of agricultural products in East Java, therefore alternative fuel potentials that will be obtained will also be higher. Research conducted that is aimed at finding out the characteristics of solid fuel (briquettes) include: Braket's heat values, briquette water content, briquette gray content and drop tests on briquettes using a mixture of corn cobs and rice straw. Variation of a mixture between corn cobs and rice straw of 1 kg, where 1 kg of corn cob and rice straw uses a mixture ratio of 90%: 10%, 80%: 20%, 70%: 30% and 60%: 40% by using flour adhesive kanji of 0.001 kg. Also uses two pressure variations, namely: A = 2500 kPa and B = 5000 kPa used in briquettes. The results of research from the briquette characteristics such as: the highest heat value using a 90% corn cob mixture and 10% rice straw obtained at 5546.74 Cal/gram. The most optimal water content uses an emphasis load of 5000 kPa using a 90% corn cob mixture and 10% rice straw obtained a value of 11.30%. The most optimal ash content also uses an emphasis load of 5000 kPa using a 90% corn cob mixture and 10% rice straw obtained a value of 20.58%. While the drop test value on the briquette uses a 5000 kPa pressing load using a 60% corn cob mixture and 40% rice straw obtained a value of 11.10% the large reduction of pasticles when dropped from a height.

* Corresponding author: rullie.annisa@trunojoyo.ac.id

1 Introduction

Biomass is an agricultural waste material that can be used as a solution in overcoming the energy crisis that occurs. In addition, biomass is a waste produced from agriculture that can be converted into renewable energy, so it is often used and used as a power plant or used in the industrial world [8]. The biomass obtained needs to be changed in shape into a briquette form, where the process of making briquettes is carried out by the process of compaction of organic material so that it can turn into solid material [9]. The benefits of biomass that are converted into briquettes can be used into environmentally friendly fuels [10].

Corn cobs and rice straw are most commonly found in East Java, because the average work of the surrounding community is the agricultural sector. Corn cobs can also reduce sulfur content and have content in accordance with the SNI briquette standards [2]. Where the composition in corn cobs has a crude fiber found in corn cobs quite high at around 33%. While the composition of cellululosa is 44% and the composition of lignin is 33.3%, with this content corn cobs can be used as alternative fuels [7]. In addition, corn cobs and rice straw are residual waste from agricultural products that can be used into alternative fuels [4].

The study was conducted [13], namely corn cobs converted into briquettes made with a pressure of 22.42 kg/cm² and 44.80 kg/cm², the ash content and the resulting heat values are better using greater pressure variations. The study was also conducted by [1] mixing corn cobs with rice husks into briquettes, where variations in the mixture of corn and rice husks are 80:20, 70:30, 60:40 and 50:50. The durability produced is the maximum when using a variation of 50% corn cob and rice husk 50% [2]. Corn cobs are mixed with coconut meat pulp. Research was carried out by [15] Variations of 80 psi and 90 psi pressure variations, besides that variations mixed with coconut meat and corn cobs of 750 grams: 250 grams, 500 grams: 50 grams and 250 grams and 750 grams. The lowest ash content and the highest heat value using a pressure of 80 psi with a mixture of 750 grams: 250 grams. From the discussion of several studies of corn cobs using mixed variations and using larger pressure has not received better briquette characteristic.

Research on rice straw was also conducted [14] Briquettes made with variations in the size of 5 mm, 10 mm and 15 mm of rice straw, the results obtained increase in the size of the briquette material can increase the consumption of briquette energy. The study was conducted by [11] making rice straw briquettes with the aim to determine the effect of temperature, pressure and size of the briquette material, the results obtained are the temperature increases with the increase in pressure given and the finer the material is used in the research process. From some of the descriptions that have been discussed above, the research that will be carried out aims to determine the characteristics of the briquette (solid fuel) includes: the heat of briquettes, briquette water content, gray content of briquettes and drop tests on briquettes using a mixture of corn and straw cobs Rice, variations in a

mixture of corn cobs with rice straw 90%: 10%, 80%: 20%, 70%: 30% and 60%: 40% using starch adhesive. Besides using the loading (pressing) of 2500 kPa and 5000 KPA given to the briquette results.

2 Methods

The method used in this study is the experimental method during the research process, while the research test site was tested in the ergonomics laboratory and the laboratory of the automation and robotics system for 3 months. The following is a hydraulic pressing tool on the briquette material used in Figure 1. The additional tool used is a pounding device, sieve with a mesh 50 and a briquette mold with a height of 6 cm and a diameter of 2 cm.

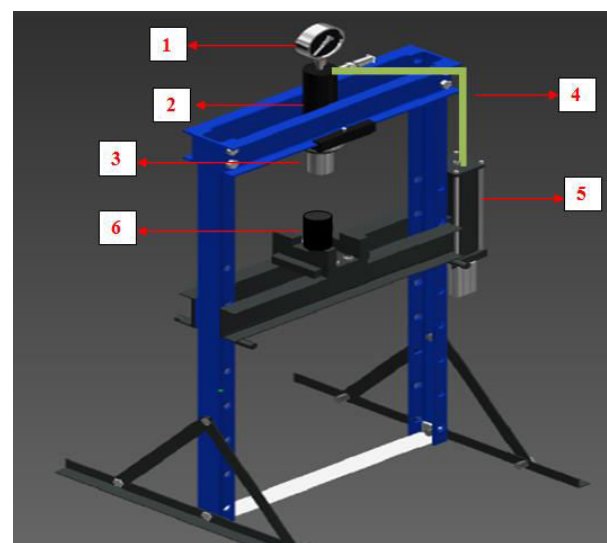

Caption:

- | | |
|-------------------|-------------------|
| 1) Pressure Gauge | 4) Fulida Hose, |
| 2) piston house | 5) Pump house |
| 3) Piston | 6) Briquette mold |

Fig. 1. Briquette pressing tool.

The material used by corn cobs and rice straw as biomass as shown in Figure 2. water and starch. The material is obtained from the rice field area in Arosbaya District, Bangkalan Regency.



Fig. 2. Carbonized biomass (a) corn cob, (b) rice straw.

Testing process

The testing process is a parameter of determining the characteristics and quality of the briquettes. The testing process carried out is heat values, water content and

ash content are standard SNI No.1/6235/2000 (Iskandar et al., 2019). In addition, testing was also carried out using ASTM D 440-86 R02, which was the process of testing the briquette [5].

Briquette heat value

Calorimeter bomb tools are used to determine the amount of heat values contained in briquettes (solid fuel). The test was carried out at the Bakar Motor Laboratory, Universitas Brawijaya in Malang. The tool can determine the amount of heat released by the briquettes (solid fuel) using oxygen and the volume used is also fixed [13].

Briquette water content

The process of weighing briquettes before dried and re-weighing briquettes after dried, the purpose is to determine the water content contained in the briquette material [6]. The process of weighing the material using a digital scale. From these data, it is included in Equation 1 (Salim, 2016).

$$\% \text{ water content} = \frac{BA-BK}{BK} \times 100 \quad (1)$$

Information:

BA= initial weight of the sample before dried (gram)

BK = dry weight after drying (gram)

Briquette ash content

The ash content in the briquette is measured by weighing the weight on the briquette, then inserting it into the furnace up to 550oC for 4 hours, after being obtained then weighed and enter data in Equation 2 [3].

$$\%PAC = \frac{D}{B} \times 100 \quad (2)$$

Information:

PAC = ash content (gram)

D = the weight of the combustion ash (gram)

B = Briquette weight before burning (gram)

Drop test

Drop test is a test conducted on briquettes to determine the strength of the briquette, where the testing process is dropped using a height of 200 cm. After the testing, the largest fraction of the briquettes was taken and weighed again. Calculation of the number of broken briquettes that are lost can use equation 3 [3].

$$\text{missing particles} = \frac{mA-mB}{mA} \times 100\% \quad (3)$$

Information:

mA = Briquette weight before being dropped (gram)

mB = weight after after being dropped (gram)

3 Result and Discussion

Research on making briquettes (solid fuel) was carried out using a biomass mixture, namely corn cob and rice straw, both ingredients were mixed and using a mixture variation and given a pressure load of 2500 kPa and 5000 kPa. From the results obtained, testing of briquettes, the aim is to determine the characteristics of

briquettes (solid fuel) such as the heat value of briquettes, briquette water content and briquette drop test.

Briquette heat value

[9] The value of heat in the briquette is a test carried out on the briquette material in order to obtain a large heat from each of the briquettes produced, the results of the magnitude of the heat of the heat in the mixture of corn and rice straw are shown in Figure 4. The highest heat value uses a mixture 90% corn and 10% rice straw obtained at 5546.74 Cal/gram, while the lowest heat value using a 70% corn cob mixture and 30% rice straw obtained at 4879.87 Cal/gram. The heat value is influenced by the amount of rice straw mixed in corn cobs, where the heat value continues to decline by adding rice straw by 20% and 30%. But by adding rice straw by 40% of the heat value has increased greater than a mixture of 30% rice straw. The difference in heat value is caused by the water content contained in each of the briquettes produced, therefore the water content in the briquette can have a significant effect on the heat value [15]. In addition, one of the low heat values in the briquette is also due to the large amount of ash composition [3].

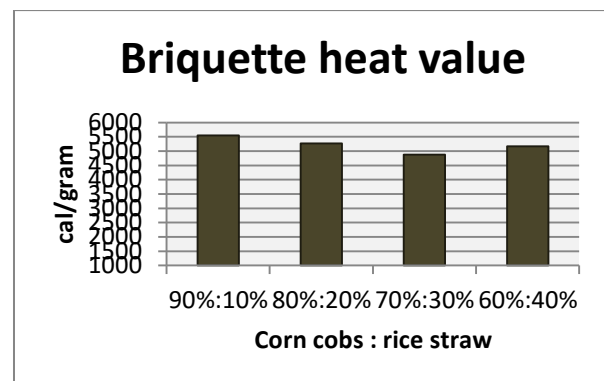

Fig. 3. The results of the heat value in the briquette

Briquette water content

The results of the water content contained in the briquette material are shown in Figure 5, where the water content produced by imposing an emphasis load of 5000 kPa is more optimal than using an emphasis load of 2500 kPa for all variations of the briquette material mixture used. The water content uses the lowest 2500 kPa pressing load using a 90% corn cob mixture and 10% rice straw obtained a value of 12.86%, while the highest uses 80% corn cob mixture and 20% of rice straw obtained a value of 22.00%. The water content uses the lowest 5000 kPa pressing load using a 90% corn cob mixture and 10% rice straw obtained a value of 10.30%, while the highest uses a 70% corn cob mixture and 30% of rice straw obtained a value of 15.00%. The temperature used is different in the carbonization process using corn cobs and rice straw, so the results of the water content obtained in briquettes also have different values. In addition, the size of the water content contained in the briquette is strongly influenced by the size of the suppression load given, where the greater the burden of the briquette

pressing will produce a relatively low amount of water [15]

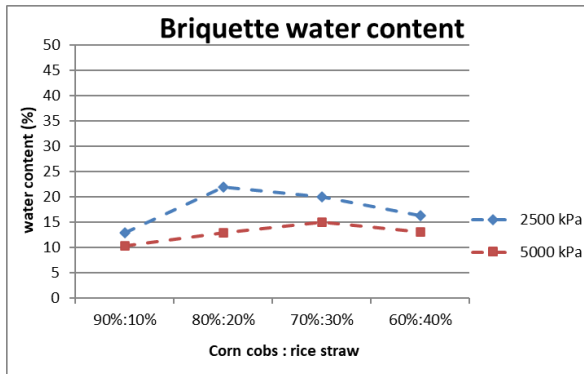

Fig. 4. The results of the water content in the briquette

Ash content

Ash content is a substance that cannot be burned again so that it leaves the remaining burning of the briquettes (solid fuel), the results of the test of the ash levels are shown in Figure 5. The value of the ash content uses the emphasis load of 5000 kPa the results are more optimal than using the pressing load of 2500 kPa for all variations in the briquette material used. Where the value of ash content is smaller, the higher the quality and quality of the briquettes produced. The ash content produced at the highest 2500 kPa emphasis uses a 70% corn cob mixture and 30% rice straw obtained a value of 32.00%, while the lowest uses a 90% corn cob mixture and 10% rice straw obtained a value of 23.35%. The ash content produced at the highest 5000 kPa pressing uses a mixture of 70% corn cob and 30% rice straw obtained a value of 25.45%, while the lowest uses a 90% corn cob mixture and 10% rice straw obtained a value of 20.58%. The result of ash content is influenced by a mixture of corn cobs and rice straw that have been used, where the less number of additional rice straw to corn cobs, the higher value of ash levels will be obtained. The ash content produced by briquettes is getting smaller in the briquettes will produce a very high heat value. Therefore the ash content can be influenced by the heat value contained in the briquette [13].

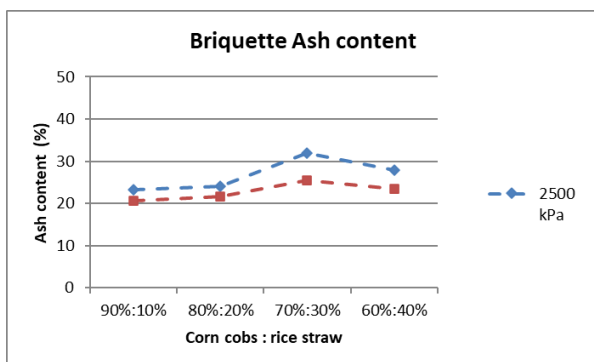

Fig. 5. The results of the ash content in the briquette

Briquette drop test

Drop test briquette aims to determine the level of resistance of briquettes to shocks during the transportation process and storage of materials [5], the

results of the drop test test on the briquette are supported in Figure 6. The drop test produced with an emphasis load of 5000 kPa is more Maximum compared to using an emphasis load of 2500 kPa for all variations in the briquette material used. The greater the emphasis given, it will increase the level of density in each briquette particle, besides that the briquette constituent particles will also be stronger and the more bound to each other [3].

The drop test value continues to decrease with a reduction in a mixture of corn cobs and the increase in the number of mixed rice straw. The highest 2500 kPa pressing load uses 90% corn cob mixture and 10% rice straw obtained a value of 33.33%, while the lowest uses a 60% corn cob mixture and 40% rice straw obtained a value of 16.28%. The highest emphasis of 5000 kPa using a 90% corn cob mixture and 10% rice straw obtained a value of 28.21%, while the lowest uses a 60% corn cob mixture and 40% rice straw obtained a value of 11.10%. The drying process in the briquette can also affect the size of the drop test results, because the binder used can be maximally binding if the drying is done optimally.

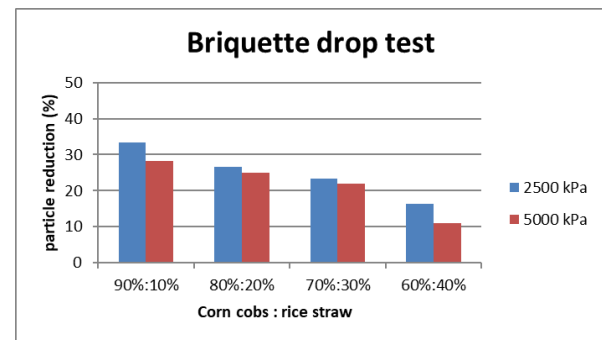

Fig. 6. The results of the drop test in the briquette

4 Conclusion

Research on briquettes (solid fuel) that has been carried out using agricultural biomass (mixture of corn and rice straw cobs) and 2500 kPa briquette suppression load and 5000 kPa concluded including the highest heat value using a mixture of 90% corn cobs and 10% rice straw obtained by 5546.74 Cal/gram, then using a slight mixture of rice straw can increase the resulting heat value; The most optimal water content uses the emphasis load of 2500 kPa using a 90% corn cob mixture and 10% rice straw obtained a value of 12.86%. While using 5000 kPa also uses a 90% corn cob mixture and 10% rice straw obtained a value of 10.30%; The most optimal ash content at the emphasis load of 2500 kPa uses a 90% corn cob mixture and 10% rice straw obtained a value of 23.35%. Whereas the pressure of 5000 kPa uses a 90% corn cob mixture and 10% rice straw obtained a value of 20.58%; The drop test uses an emphasis load of 2500 kPa using a 60% corn cob mixture and 40% rice straw obtained a value of 16.28%. Whereas using an emphasis load of 5000 kPa using a 60% corn cob mixture and 40% rice straw obtained a value of 11.10%

reduction in briquette particles when dropped from a height.

References

- Ajimotoke, H. A., Ibitoye, S. E., Odusote, J. K., Adesoye, O. A., & Omoniyi, P. O. (2019). Physico-Mechanical Characterisation of Fuel Briquettes made from Blends of Corn cob and Rice Husk. *Journal of Physics: Conference Series*, 1378(2). <https://doi.org/10.1088/1742-6596/1378/2/022008>
- Arman, M., Makhsud, A., Aladin, A., Mustafiah, M., & Abdul Majid, R. (2017). Produksi Bahan Bakar Alternatif Briket Dari Hasil Pirolisis Batubara Dan Limbah Biomassa Tongkol Jagung. *Journal Of Chemical Process Engineering*, 2(2), 16. <https://doi.org/10.33536/jcpe.v2i2.161>
- Briyatendra, E. I., & Widayat, W. (2019). Pengaruh ukuran partikel dan tekanan kompaksi terhadap karakteristik briket limbah daun cengkeh. 14–22.
- Hamidah, L. N., & Rahmayanti, A. (2017). Optimasi Kualitas Briket Biomasa Padi dan Tongkol Jagung dengan Variasi Campuran Sebagai Bahan Bakar Alternatif. *Journal Of Research and Technology*, 3(2), 70–79.
- Handra, N., Indra, A., & Purnama, I. (2020). Briket Biomassa Berbahan Dasar Serat TKKS Dengan Penambahan Serbuk Pinus dan Kanji pada Sistem Screw Ekstruder Terhadap Kekuatan. 2020, 122–128.
- Iskandar, N., Nugroho, S., & Feliyana, M. F. (2019). Uji Kualitas Produk Briket Arang Tempurung Kelapa Berdasarkan Standar Mutu Sni. *Jurnal Ilmiah Momentum*, 15(2). <https://doi.org/10.36499/jim.v15i2.3073>
- Lestari, L., Aripin, Yanti, Zainudin, Sukmawati, & Marliani. (2010). Analisis Kualitas Briket Arang Tongkol Jagung Yang Menggunakan Bahan Perekat Sagu Dan Kanji. *Jurnal Aplikasi Fisika*, 6(2), 93–96.
- Li, Z., & Xue, Z. (2015). Reviewe of Biomass Energy utilization technology. *Ic3me*, 1147–1150. <https://doi.org/10.2991/ic3me-15.2015.222>
- Oladeji, J. . (2015). Theoretical aspects of biomass briquetting: A Review Study. *Journal of Energy Technologies and Policy*, 5(3), 72–82. <https://www.iiste.org/Journals/index.php/JETP/article/view/20797>
- Pilusa, T. J., Huberts, R., & Muzenda, E. (2013). Emissions analysis from combustion of eco-fuel briquettes for domestic applications. *Journal of Energy in Southern Africa*, 24(4), 30–36. <https://doi.org/10.17159/2413-3051/2013/v24i4a3143>
- Rhofita, E. I. (2020). The Characterization of Rice Straw Briquette as an Alternative Fuel in Indonesia. 304–309. <https://doi.org/10.5220/0008908203040309>
- Salim, R. (2016). Karakteristik dan Mutu Arang Kayu Jati (*Tectona grandis*) dengan Sistem Pengarangan Campuran pada Metode Tungku Drum (The Quality and Characteristics of Teak (*Tectona grandis*) Charcoal Made by Mixed Carbonisation in Drum Kiln). *Jurnal Riset Industri Hasil Hutan*, 8(2), 53–64. <https://doi.org/10.24111/jrihh.v8i2.2113>
- Sunardi, Djuanda, & Mandra, M. A. S. (2019). Characteristics of charcoal briquettes from agricultural waste with compaction pressure and particle size variation as alternative fuel. *International Energy Journal*, 19(3), 139–147.
- Wang, Y., Wu, K., & Sun, Y. (2018). Effects of raw material particle size on the briquetting process of rice straw. *Journal of the Energy Institute*, 91(1), 153–162. <https://doi.org/10.1016/j.joei.2016.09.002>
- Wijianti, E. (2017). Briket Arang Berbahan Campuran Ampas Daging Buah Kelapa dan Tongkol Jagung. *Jurnal Teknik Mesin*, 3(1), 30–35.