

Electric Parameter Measurement on Main Generator Based on IoT for Safe Operational Feasibility

Sri Mulyanto Herlambang¹, Agus Dwi Santoso¹, Stefano Cirillo², Bambang Bagus H³

¹Politeknik Pelayaran Surabaya, Surabaya, Indonesia

²University of Salerno, Italy

³Politeknik Penerbangan Surabaya, Surabaya, Indonesia

suksesbareng20@gmail.com,

Abstract. The generator is the main source of electricity in the ship that will drive all activities on the ship. With the source of electricity supplied by the generator, human work will become lighter because it is helped by electrical energy. In order for the generator to work properly, it requires maintenance and must always be well controlled, so that the parameters generated by the generator must always be maintained by monitoring these parameters automatically using an ESP32 microcontroller. The parameters measured are current, voltage, power, frequency, work factor, KWh, RPM, temperature and vibration. By measuring the magnitude of these parameters can later be utilised as variables for maintenance and repair of the generator. The sensor used to measure the electrical parameters is the PZEM 004t module because it can measure all electrical quantities of the generator, while the temperature uses a DS18B20 sensor and vibration uses a SW-420 sensor module. Then to measure RPM using a potentiometer. The measurement results are displayed on the smartphone screen on the platform using Internet of Things (IoT) technology sent from the engine room.

Keywords. ESP32, IoT, Monitoring, Generator, Electric Parameter.

1. Introduction

For the smooth operation of the ship, facilities and infrastructure are needed for passenger, goods or fish transport. To run the ship, a source of electricity is needed to drive these facilities and infrastructure, especially the main engine. Automation is an option for operating equipment on ships to be safe in helping to relieve the work of humans who have tired time in operating ships. In automation, equipment monitoring is also needed, monitoring the main power source on the ship requires special attention because it is the driving source of all activities on the ship. To meet the electricity needs on the ship, a generator is functioned which consists of the main generator and auxiliary generator.

Generators on ships have the main function to supply electrical power needs on the ship. Electrical power is used to drive equipment on the ship, such as engine rooms and machines on deck, ship communication and navigation systems, lighting, ventilation, kitchen equipment, sanitary systems, alarms, cold storage, fire detection systems, and other machines. The ship's power is generated using the prime mover and alternator working together. For this, alternating current generators are used in ships. Generators work on the principle that when the magnetic field around a conductor varies, a current is induced in the conductor. The generator consists of a set of stationary conductors wound in coils on

an iron core. This is known as the stator. Rotating magnets called rotors rotate inside this stator generating a magnetic field. This field cuts through the conductor, generating an induced EMF or electromagnetic force as the mechanical input causes the rotor to rotate. The generator functions as a power plant in a ship[1] that can be driven automatically, the main source of power that fulfils all electrical systems, if it fails it will automatically be switched to an auxiliary generator automatically so all system parameters contained in the generator must be adequate so that they can anticipate the workload that requires electricity on the ship. Human work will be light with the help of equipment with electric power. Equipment on ships that use electricity are lighting and ship navigation that support the system to work[2] as their respective functions. Electrical energy on ships is very important and often encountered because it acts as a power source for equipment that requires electricity[3]. Large passenger ships require 2 or 3 sub-distribution of electrical power for the operation of equipment on a ship, load centre switchboards must be available for electrical distribution.

In order for the electrical parameters of the generator output used on the ship to always be monitored, there is no need to check at the control panel every time, so a device is needed that can measure and display the electrical parameters of the generator in real time, so that the electricity needs on the ship will be easily monitored using IoT (Internet of Things) technology to distribute and monitor[4] through Android displays. IoT is the phenomenon of physical objects, embedded with sensors and actuators, online and interacting with other Internet-enabled devices such as smartphones and cloud computing services[5]. IoT technology has been embraced by Silicon Valley as well as many leading companies; for example, General Electric has launched the Industrial Internet, Intel has an IoT group, and Cisco calls it "fog Computing". The National Science Foundation has prioritised this development under their Cyber-Physical Systems (CPS) programme across the Computer & Information Science & Engineering (CISE) Directorate. Even large software companies like Google, Facebook, and Amazon are starting to invest heavily in hardware again. The electricity supply on the ship from the generator will always be monitored, if the main generator is not enough to provide supply or has a problem it will automatically be helped or replaced by an auxiliary generator.

2. Device Design

2.1. Hardware Design

The first step is to make a hardware design made in the form of a block diagram, then explain in each block diagram the function and workings of each block.

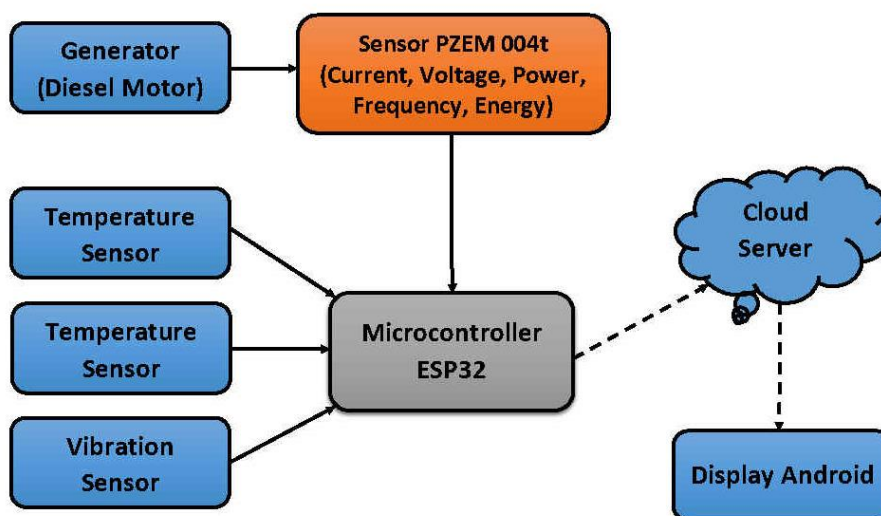

Figure 1. Block Diagram of System

A shipboard generator is a device used to generate electricity on board a ship. Ships, both small and large, require a source of electricity to operate various onboard equipment and systems, such as lighting, navigation equipment, communications, engines, galley equipment, and more. A ship's generator is a critical component in the ship's electrical system that ensures a reliable supply of electricity throughout the vessel, regardless of whether it serves as a passenger ship, cargo ship, or warship. Ship generators can operate using a variety of power sources, including diesel engines, gas engines, gas turbines, or electric motors. Shipboard generators typically use diesel engines as the primary source[6] because diesel generators tend to be reliable, efficient, and capable of operating for long periods of time[7]. The capacity of a ship's generator must be designed to meet the ship's electrical requirements, which can vary greatly depending on the ship type, size, and equipment used. Large passenger vessels or cargo ships will require generators with larger capacities than small vessels. Ship generators are usually equipped with sophisticated monitoring and control systems to ensure stable electricity availability. This includes automated systems that can detect load changes and regulate the generator output automatically. Ship generators need to be highly reliable[8] as ships often operate in harsh marine environments. Therefore, good care and regular maintenance are essential to maintain the generator's performance. Ships are usually also equipped with emergency generators that will ensure a backup source of electrical power if the main generator fails. The generator is a shipboard power plant that will have its parameters measured for safe operation. The parameters measured are voltage, load current, power, frequency, and energy used[9].

The PZEM-004T module is a multifunctional sensor module that functions to measure power, voltage, current and energy contained in electric current[10]. This module is equipped with an integrated voltage and current sensor (CT). In use, this tool is specialised for indoor use and the load installed must not exceed the specified power. The PZEM-004T module is an electronic device used to measure various electrical parameters in power systems, such as voltage, current, active power, reactive power, apparent power, power factor, and the amount of electrical energy consumed. This module is often used in applications related to monitoring and measuring electrical energy, such as in energy management systems, automatic control systems, or energy efficiency monitoring. The PZEM-004T module is often used in energy monitoring and control applications, such as in household electricity consumption monitoring systems, solar panel performance monitoring systems, industrial energy management systems, and so on. This module helps users to monitor and optimise the use of electrical energy, as well as measure the efficiency of electrical systems. Some of the common features of the PZEM-004T module include voltage measurement, current measurement, active power measurement, reactive power measurement, apparent power measurement, power factor, energy consumption measurement, communication interface, and LCD display. Voltage measurement modules are used to measure mains voltage within a specified range, typically from 80V to 260V AC. The current measurement module is also capable of measuring electric current within a specified range[11], such as 0 to 100A. The active power measurement part of the PZEM-004T module can measure active power, which is the power used to do real work in an electrical circuit. In addition to active power, the module can also measure reactive power, which is power that is not used to do real work and is often required for electrical system purposes. The module also provides measurements of apparent power, which is the result of combining active power and reactive power. The module calculates the power factor, which reflects the efficiency of electrical energy use in the system. The PZEM-004T is capable of measuring the total energy[12] that has been used in the system, which is usually measured in kWh (kilowatt-hours). This module is often equipped with a communication interface such as RS-485 or TTL/UART, which allows users to connect it to a microcontroller or computer for further monitoring and control. Many PZEM-004T modules are equipped with an LCD screen that displays measurement data directly.

In addition, there is an ESP32 microcontroller that will read data from the PZEM sensor then process the data and send the data to the cloud database. If there is data that does not match the specifications of the generator whose parameters are measured, this microcontroller will send a notification to the smartphone via the cloud server. Then the data sent by the microcontroller will be stored in a cloud database, namely Firebase. The data will be stored in tag variables to be used by smartphones as

information media. Generator parameter data is displayed on an android smartphone as information that is used by the user to determine the performance of the generator, as well as providing notification information if the measured generator parameters do not match the specifications of the diesel motor generator.

2.2. Software ESP32 Design

To run the hardware system, a programme is required, which is designed using Arduino IDE software by first installing the board for ESP32. ESP32 is a series of feature-rich MCUs with integrated Wifi and Bluetooth connectivity for various applications[13]. Espressive Systems, China, manufactures them. The ESP32 is cheap [14] and almost ten times faster than the Arduino Uno and is a 32-bit versatile device. ESP32 IC developers make small module boards with edge constellations. One of the popular versions of such a module board is called ESP-WROOM-32. It is a dual-core, 32-bit microcontroller unit, and all the cores can be controlled individually. It has integrated Wi-Fi, Bluetooth, and Bluetooth Low Energy with multiple digital and analogue I/O pins. After the board is installed then include the library in the program that will be created, to run the existing system. Then the microcontroller will read Voltage, current, power, energy, and frequency using the PZEM module via TX, RX serial communication from ESP32 on pins 16 and 17. After the data is read, it is sent to the cloud server to be stored in the Firebase database using the JSON method.

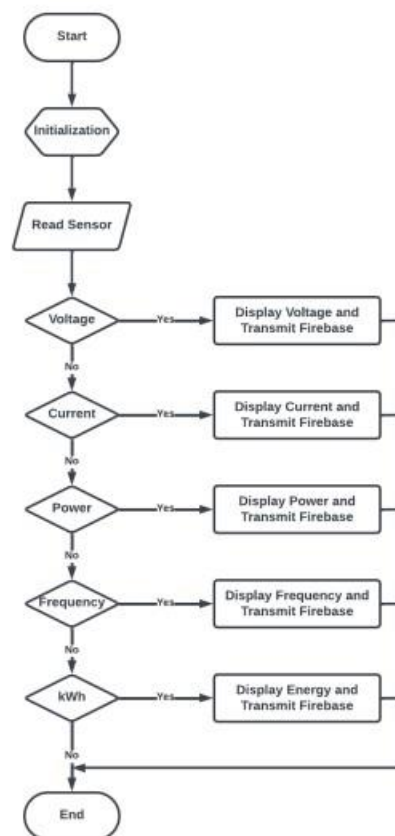

Figure 2. ESP32 System Flowchart

2.3. Software Android Design

To connect the monitoring system for measuring diesel motor generator parameters using Internet of Things technology, one of them is the creation of a mobile program on an Android smartphone. Android smartphones function as data viewers for diesel motor generator parameters, which are made using App

Inventor 2 software in the form of program blocks that are arranged to produce a system that can run on the Android platform.

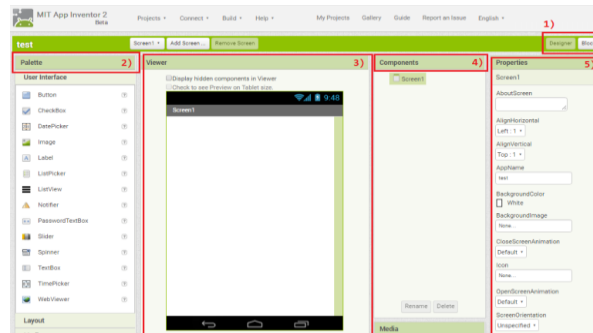

Figure 3. App Inventor 2 Software

2.4. *Firestore Cloud Server*

To store measurement data in the Internet of Things technology, it uses a cloud server provided by Google and is free of charge with a capacity of about 16 GB. Firestore is a cloud-based application development platform provided by Google[15]. Firestore provides a variety of services that allow developers to build, manage, and launch web and mobile applications more quickly and easily[16]. One of the important services in Firestore is Firestore Cloud Server, also known as Firestore Cloud Functions. It is a serverless service that allows developers to run server code in Google's cloud environment. Firestore Cloud Server is a very useful tool for developers who want to manage their application server logic in the cloud without having to worry about configuring server infrastructure. With Firestore Cloud Server, it can build responsive and scalable applications more easily, and save time and resources in application development[17]. Some of the key concepts and features associated with Firestore Cloud Server include serverless, programming language, HTTP request handling, event-driven, auto-scalability, firestore integration, easy deployment, and task scheduling. Firestore Cloud Server is a serverless solution, which means developers don't have to worry about managing physical server infrastructure. Firestore Cloud Server manages resource usage and scales automatically according to application needs. Firestore Cloud Server supports a variety of programming languages, including JavaScript, Node.js, Python, Go, and others. Developers can choose the language that best suits their needs. Firestore Cloud Server allows developers to handle HTTP requests, which means it can create APIs or web services easily. It can respond to HTTP requests by developing appropriate Firestore functions. Firestore Cloud Server is very good at handling events or data changes in the application, it can create functions that are activated by certain events, such as data changes in the Firestore Realtime Database, Firestore Firestore, or Firestore Authentication. Firestore Cloud Server automatically handles application scale, meaning that if the application becomes popular and usage increases, Firestore will automatically add the necessary resources. can combine Firestore Cloud Server with other Firestore services, such as Firestore Authentication, Firestore Realtime Database, Firestore Firestore, and others, to build complete applications.

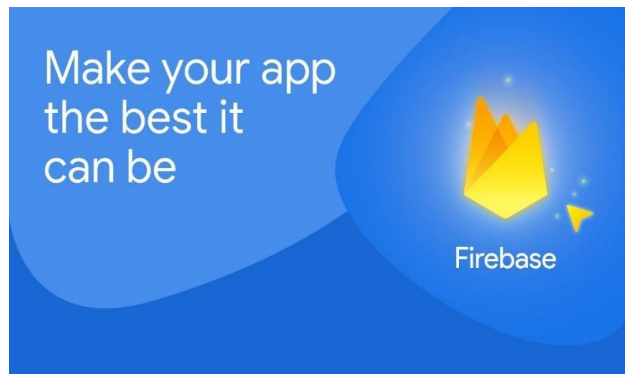

Figure 4. Firebase Software

Firebase provides tools and command lines that make it easy for developers to deploy Firebase functions to the Firebase cloud environment. Firebase Cloud Server can use to schedule and execute scheduled tasks, such as cleaning data or sending automated notifications. The data generated by the PZEM sensor is all stored in a database, namely Firebase. To create this database, first access the URL address: firebase.google.com, then enter according to the questions given and the database used is a realtime database.

3. Device Testing and Results

3.1. Hardware Implementetion

This subchapter describes the electronic circuit used to measure electrical parameters in the ship's main generator. The electronic circuit consists of several electronic circuit blocks, namely the PZEM 004t sensor circuit, Organic Light-Emitting Diode (OLED) display, temperature sensor circuit, vibration sensor circuit, and RPM sensor circuit.

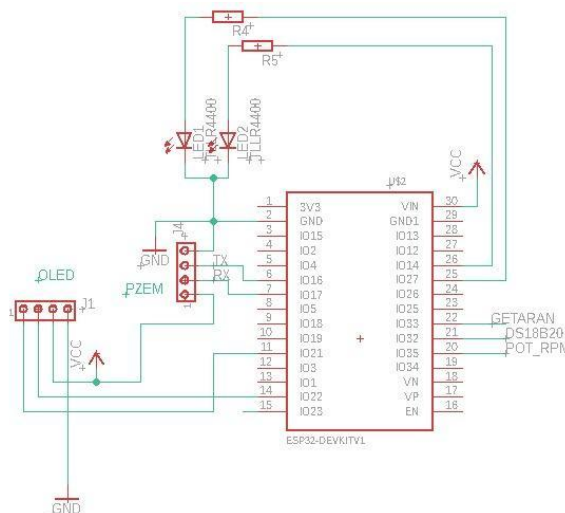

Figure 5. Complete Generator Parameter Measurement Circuit

The PZEM sensor is an electronic circuit module used to obtain measurement data of electrical parameters, namely power, voltage, current, power factor and frequency[18]. The circuit module is connected serially (serial communication) with the ESP32 microcontroller and fan. These measurements are crucial for understanding and managing the electrical characteristics of a system or appliance, and the PZEM sensor simplifies this process.

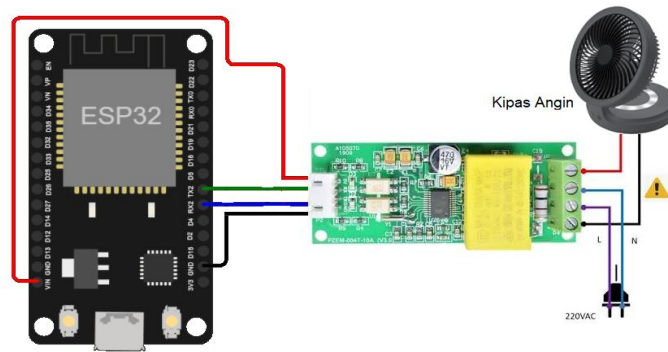

Figure 6. PZEM Sensor Circuit Connected with Fan Load

For the measurement of electrical parameters through the PZEM module, data is sent serially to the ESP32, then the data is processed through the function programme void sensor_PZEM() to validly generate such electrical parameters.

This OLED display circuit not only displays the electrical parameters measured through the PZEM sensor, but also displays the temperature, vibration and RPM parameters of the generator. The OLED display circuit[19] can be seen in Figure 7(a). The temperature sensor circuit uses the electronic component IC DS18B20. The function of this circuit is to measure the temperature of the generator that is working, this is done to find out the maximum temperature allowed to occur in the generator so that immediate action is taken before damage to the generator. A temperature sensor circuit using the electronic component IC DS18B20 is one way to measure temperature with high accuracy. The DS18B20 IC is a 1-Wire based digital temperature sensor that is very popular due to its accuracy and its ability to communicate with microcontrollers or other devices via the 1-Wire protocol. The components required in the following research are the DS18B20 temperature sensor, microcontroller, 4.7k ohm resistor (pull-up resistor), jumper cables, and breadboard (optional). The temperature sensor circuit can be seen in Figure 7(b).

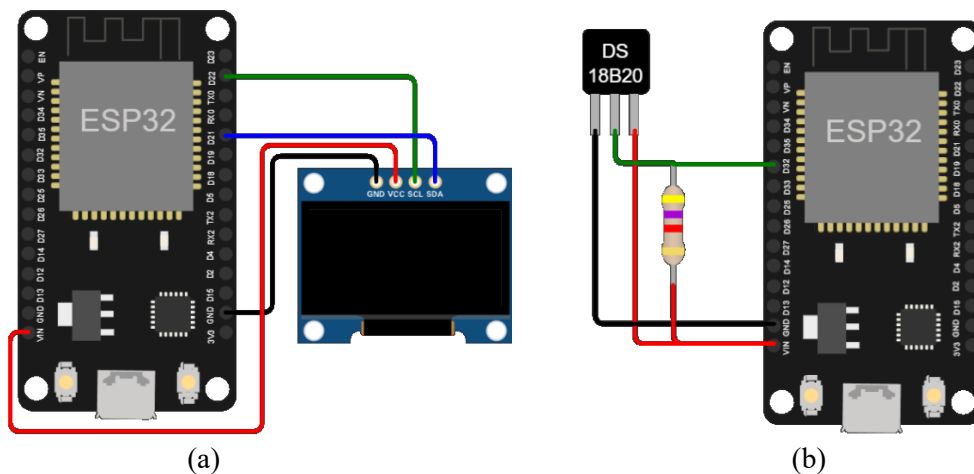

Figure 7. ESP32 Layout
 (a) With OLED Display and (b) With Temperature Sensor

A vibration sensor (SW-420) can be used to detect the presence or absence of vibration[20]. The sensor will not provide an analogue signal to indicate the intensity of vibration, but rather will indicate whether or not there is vibration through a digital output. The SW-420 vibration sensor is a sensor used to detect vibration or shock in various applications[21]. It generates an output signal when vibration exceeds a certain threshold. SW-420 is often used in projects that require vibration monitoring or shock

detection, such as security, earthquake detection, and so on. It is important to remember that the SW-420 vibration sensor is more suitable for detecting fairly strong shocks or vibrations. For applications that require more subtle vibration detection, you may need to use a more sensitive sensor or an accelerometer sensor designed specifically for that purpose. To determine what constitutes vibration, one must adjust the sensitivity of the sensor via the built-in potentiometer (more details will be provided later). This vibration sensor has the ability for sensitivity adjustment. To adjust the sensitivity of the vibration can be done by turning the potentiometer with a small screwdriver. The vibration sensor circuit using the main component of the LM393 Comparator IC is used as a voltage comparator in this vibration sensor module. Pin 2 of LM393 is connected to the Preset (10kΩ Pot) while pin 3 is connected to the vibration sensor. The comparator IC will compare the threshold voltage set using the preset (pin2) and the Vibration Sensor pin (pin3). The potentiometer is used to set the threshold (sensitivity) of the digital output. The vibration switch detects vibration amplitude that exceeds the reference voltage (comparator voltage), resulting in the output of IC LM393 from high to low. While the vibration sensor module interface circuit with Esp32 can be seen in the following figure.

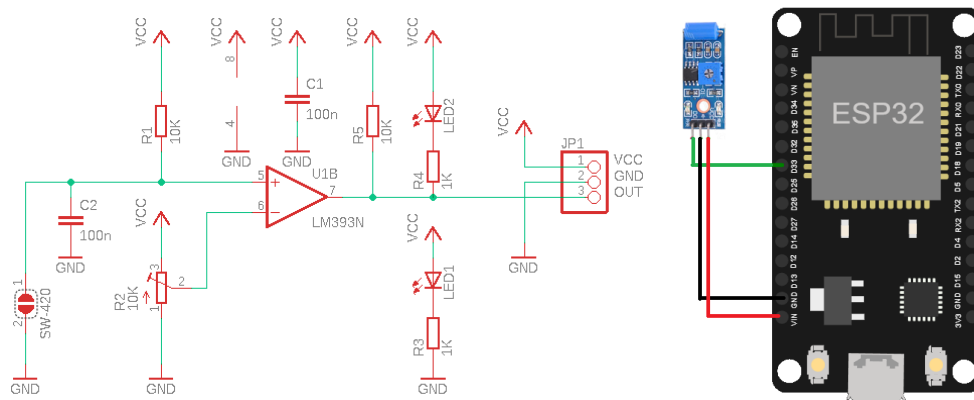

Figure 8. Vibration Sensor Module and Configuration with ESP32 Module

The RPM measurement circuit of the generator is simulated using a potentiometer. The schematic of the circuit can be seen in Figure 9.

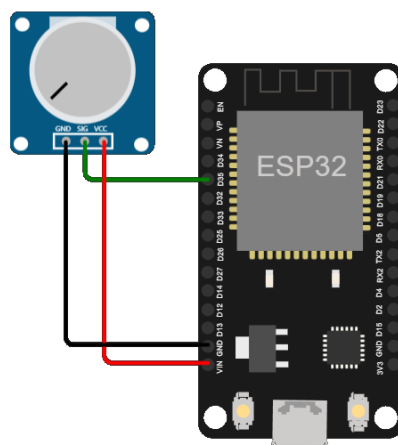

Figure 9. Simulation of the Generator RPM Meter Circuit

The process of measuring RPM by reading the voltage output from the potentiometer which has a range of changes between 0V to 3.3V. Then the voltage is converted into digital data with ESP32

through reading the analogue input. The converted digital data has a range from 0 to 4095. The range of values can be calculated using equation 1 and then mapped using a function programme to convert digital data into RPM.

$$VinA = \frac{Data\ konversi}{2^{12}-1} \times 3,3V \tag{1}$$

where $VinA$: analogue input voltage
 Conversion data : conversion value of analogue voltage to 12 bit digital data
 $2^{12} - 1$: ADC (Analog to Digital converter) resolution 12 bit ESP32 = 4095

3.2. Software Implementetion

Implementation of software on monitoring the electrical parameters of temperature, vibration and RPM on the ship's generator using C++ which is designed using the Arduino IDE and android applications using App Inventor using MIT App Inventor. Arduino IDE is software that is used to create programming sketches or in other words, Arduino IDE as a medium for programming on the board that you want to program. Arduino IDE is useful for editing, creating, uploading to the specified board, and coding certain programmes. Arduino IDE is made from the JAVA programming language, which is equipped with a C / C ++ (wiring) library, which makes input / output operations easier. The discussion of C++ software has explained each function program related to ESP32 which is used to read the parameters of the ship generator in the subchapter of the implementation of the squeeze device, while the discussion of the android application for monitoring the measurement of these parameters is explained as follows. In designing the android application is divided into 2 parts, namely the design view and block coding. The design view of the android application as shown in Figure 10 is used to display the generator parameters and the logo of “Politeknik Pelayaran”.

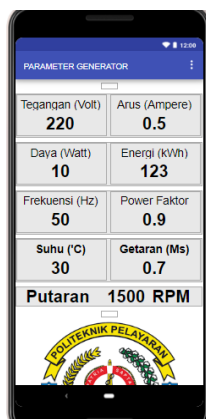
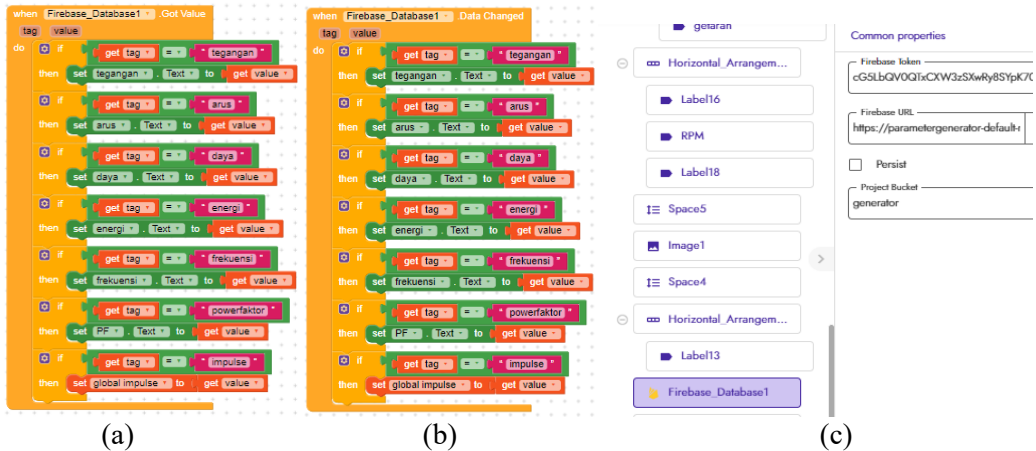

Figure 10. Design View

The block coding section can be seen in Figure 11 (a) and (b). The block coding functions to read the generator parameter data in the Google cloud in the form of a firebase database stored in the cloud, while the token and firebase database url can be seen in Figure 11 (c).



(a) Prosedur Menampilkan Parameter di Layar Mobile Phone
 (b) Procedure for Saving Data Changes to the Cloud
 (c) Token and Database Url

3.3. Device Testing

Testing the device for monitoring the parameters of the main generator on the ship is simulated with a fan as a substitute for the generator. The fan has specifications of 220 V voltage, 50 Hz frequency, and 55 W power consumption. The test was carried out for 2 hours and the first time the fan turned on the display on the monitor screen showed the results of the measurement of electrical parameters and added to the measurement of vibration, RPM and temperature parameters.



Figure 12. Device Prototype with Fan Load



(a) (b)
Figure 13. Display of Device Testing Results
(a) First hour (b) Second hour

Figure 13a is the result of measuring electrical parameters for the first hour and the result of measuring electrical parameters for the second hour is shown in Figure 13b where the results of measuring parameters in the first hour and the second hour are the same, but there is a slight difference in the value of kWh and temperature in the first and second experiments. The kWh value in the first hour is 0.001 kWh, while in the second hour it is 0.007 kWh. The temperature in the first experiment was 25°C and in the second experiment (second hour) was 32°C.

The values of the parameter measurement results are listed in Table 1. In this study, researchers used 8 trials with a time span of 15 minutes. Some constant value measurement results are in the measurement of voltage, load power, power factor, frequency, current, RPM, and vibration, while the kWh and temperature measurement results show different values in each experiment.

Table 1. Device Testing Results

Minute	Voltage (volt)	Load Power (watt)	Power Factor	Frequency (Hz)	Current (Ampere)	KWh	RPM	Vibration (Ms)	Temperature (°C)
1	233,3	53,4	0,98	50	0,23	0,01	1500	0,78	25
15	233,3	53,4	0,98	50	0,23	0,02	1500	0,78	26
30	233,3	53,4	0,98	50	0,23	0,03	1500	0,78	27,9
45	233,3	53,4	0,98	50	0,23	0,04	1500	0,78	30,1
60	233,3	53,4	0,98	50	0,23	0,05	1500	0,78	31,2
75	233,3	53,4	0,98	50	0,23	0,07	1500	0,78	32
90	233,3	53,4	0,98	50	0,23	0,08	1500	0,78	33

115	233,3	53,4	0,98	50	0,23	0,09	1500	0,78	34
120	233,3	53,4	0,98	50	0,23	0,12	1500	0,78	34,5

4. Conclusion

This equipment can work as intended, namely being able to monitor the measurement results of generator parameters, namely voltage, power, KWh, current, power factor, temperature, RPM and vibration. After testing for 2 hours the electrical parameters are kept constant, except for the temperature parameter but still within the allowable range. These parameters can be monitored via android mobile phone so that it can make it easier for operators to see the condition of the generator anywhere and can be known quickly if a fault occurs, before more severe generator damage occurs.

References

- [1] P. Michalopoulos, G. J. Tsekouras, F. D. Kanellos, and J. M. Prousalidis, "Optimal Selection of the Diesel Generators Supplying a Ship Electric Power System," *Appl. Sci.*, vol. 12, no. 20, 2022, doi: 10.3390/app122010463.
- [2] P. Pan, Y. Sun, C. Yuan, X. Yan, and X. Tang, "Research progress on ship power systems integrated with new energy sources: A review," *Renew. Sustain. Energy Rev.*, vol. 144, no. October 2019, p. 111048, 2021, doi: 10.1016/j.rser.2021.111048.
- [3] V. Shagar, S. G. Jayasinghe, and H. Enshaei, "Effect of load changes on hybrid shipboard power systems and energy storage as a potential solution: A review," *Inventions*, vol. 2, no. 3, 2017, doi: 10.3390/inventions2030021.
- [4] X. Wang, "The architecture design of the wearable health monitoring system based on internet of things technology," *Int. J. Grid Util. Comput.*, vol. 6, no. 3–4, pp. 207–212, 2015, doi: 10.1504/IJGUC.2015.070681.
- [5] G. Aceto, V. Persico, and A. Pescapé, "Industry 4.0 and Health: Internet of Things, Big Data, and Cloud Computing for Healthcare 4.0," *J. Ind. Inf. Integr.*, vol. 18, no. February 2019, p. 100129, 2020, doi: 10.1016/j.jii.2020.100129.
- [6] J. Kavil Kambrath *et al.*, "Modeling and Control of Marine Diesel Generator System with Active Protection," *IEEE Trans. Transp. Electrification*, vol. 4, no. 1, pp. 249–271, 2017, doi: 10.1109/TTE.2017.2764324.
- [7] A. Jafari, T. Khalili, H. G. Ganjehlou, and A. Bidram, "Optimal integration of renewable energy sources, diesel generators, and demand response program from pollution, financial, and reliability viewpoints: A multi-objective approach," *J. Clean. Prod.*, vol. 247, 2020, doi: 10.1016/j.jclepro.2019.119100.
- [8] F. D. Kanellos, G. J. Tsekouras, and N. D. Hatziargyriou, "Optimal demand-side management and power generation scheduling in an all-electric ship," *IEEE Trans. Sustain. Energy*, vol. 5, no. 4, pp. 1166–1175, 2014, doi: 10.1109/TSTE.2014.2336973.
- [9] T. Tarasiuk and M. Gorniak, "Load Sharing in Ship Microgrids under Nonsinusoidal Conditions-Case Study," *IEEE Trans. Energy Convers.*, vol. 32, no. 2, pp. 810–819, 2017, doi: 10.1109/TEC.2017.2691803.
- [10] S. George and G. B, "IoT Based Smart Energy Management System using Pzem-004t Sensor & Node MCU," *Int. J. Eng. Res. Technol.*, vol. 9, no. 7, pp. 45–48, 2021, [Online]. Available: <https://www.amazon.in/Easy-Electronics-16x2->

- [11] D. Tzelepis *et al.*, “Voltage and current measuring technologies for high voltage direct current supergrids: A technology review identifying the options for protection, fault location and automation applications,” *IEEE Access*, vol. 8, pp. 203398–203428, 2020, doi: 10.1109/ACCESS.2020.3035905.
- [12] C. D. Hantoro and S. Setiawidayat, “Monitoring and Control of 3 Phase Electrical Energy Internet of Things (IoT) Based,” *Eur. J. Electr. Eng. Comput. Sci.*, vol. 7, no. 3, pp. 80–86, 2023, doi: 10.24018/ejece.2023.7.3.522.
- [13] M. H. Zainal and C. K. Lee, “Development of Automatic Litter Box Using,” vol. 4, no. 2, pp. 529–536, 2023.
- [14] L. S. Zamel and J. R. Naif, “AN OVERVIEW SMART ASSISTANT SYSTEM FOR OLD PEOPLE,” pp. 28–36, 2023.
- [15] G. Albertengo, F. G. Debele, W. Hassan, and D. Stramandino, “On the performance of web services, google cloud messaging and firebase cloud messaging,” *Digit. Commun. Networks*, vol. 6, no. 1, pp. 31–37, 2020, doi: 10.1016/j.dcan.2019.02.002.
- [16] N. Nguyen, “Building an E-commerce Application Utilizing Firebase Cloud service,” *Metrop. Univ. Appl. Sci.*, no. Mobile Solutions, 2022.
- [17] A. Amanuel, “Supabase vs Firebase: Evaluation of performance and development of Progressive Web Apps,” no. May, 2022.
- [18] N. A. Hussien, A. A. D. Al Magsoosi, A. A. D. Al Magsoosi, H. T. Salim AlRikabi, and F. T. Abed, “Monitoring the Consumption of Electrical Energy Based on the Internet of Things Applications,” *Int. J. Interact. Mob. Technol.*, vol. 15, no. 7, pp. 17–29, 2021, doi: 10.3991/ijim.v15i07.20183.
- [19] K. H. Seol, Y. I. Kim, S. Park, and H. Nam, “Simultaneous Emission AC-OLED Pixel Circuit for Extended Lifetime of OLED Display,” *IEEE J. Electron Devices Soc.*, vol. 6, no. July, pp. 835–840, 2018, doi: 10.1109/JEDS.2018.2859271.
- [20] H. S. Songara, H. Malvi, H. Bhat, and M. Kumar, “Arduino Based Vehicle Accident Detection and Alert System using GPS, GSM Module,” 2023.
- [21] S. T. Sukenda, M. T. Wawanmaulana, S. Septiane, M. Irvan, and L. N. S. Dimas, “Use Of Vibration Sensor As Detection Of Railway In Mechanical Signaling Systems,” *J. Archaeol. Egypt/Egyptology*, vol. 17, no. 5, pp. 402–413, 2020.