



and light intensity measurement to automate various home functions, such as lighting, fan control, and appliance management.

## 2. System Design and Architecture

### 2.1 System Overview

The home automation system was designed to automate various aspects of the home environment. The architecture includes:

- **Sensors:** Motion sensors, thermal sensors, light sensors, and presence sensors.
- **Devices:** Lights, fans, appliances (microwave and washing machine), air conditioning, and exhaust fans.
- **Microcontrollers:** Arduino for sensor interfacing and control logic.



### 2.2 Sensor Integration

Sensors were integrated into the system to monitor different environmental parameters:

- **Motion Sensors:** Detect human presence in specific areas.
- **Thermal Sensors:** Measure temperature variations in different zones.
- **Light Sensor:** Measures ambient light intensity.
- **Presence Sensors:** Detect the presence of appliances.

### 2.3 Control Mechanisms

The system uses the data from sensors to control various devices:

- **Lighting Control:** Based on motion detection and light intensity.
- **Fan Control:** Activated by temperature thresholds.
- **Appliance Management:** Operated based on presence and thermal readings.
- **Night Lamp:** Controlled by ambient light levels.
- **Exhaust Fan:** Managed by temperature readings.

## 3. Implementation

### 3.1 Hardware Setup

The hardware setup involves connecting sensors and devices to the microcontroller ports. The Arduino microcontroller is programmed to read sensor data, execute control logic, and manage devices.

### 3.2 Software Development

The software, written in C++, includes:

- **Initialization:** Setting up sensor pins and device states.
- **Sensor Reading:** Functions to read data from various sensors.
- **Device Control:** Functions to set the state of devices based on sensor inputs.

#### Code Snippet:

```
// Define constants
#define ROOM_MOTION_SENSOR 1
#define KITCHEN_MOTION_SENSOR 2
#define IR_SENSOR 3
#define MICROWAVE_PRESENCE_SENSOR 4
#define MICROWAVE_THERMAL_SENSOR A0
#define WASHING_MACHINE_PRESENCE_SENSOR A1
#define WASHING_MACHINE_THERMAL_SENSOR A2
#define ROOM_THERMAL_SENSOR A3
#define KITCHEN_THERMAL_SENSOR A4
#define LIGHT_SENSOR A5

// Define variables
int room_motion = 0;
int kitchen_motion = 0;
int ir_sensor = 0;
int microwave_presence = 0;
int microwave_thermal = 0;
int washing_machine_presence = 0;
int washing_machine_thermal = 0;
int room_thermal = 0;
int kitchen_thermal = 0;
int light_intensity = 0;

// Initialize sensors
void initialize_sensors() {
    pinMode(ROOM_MOTION_SENSOR, INPUT);
    pinMode(KITCHEN_MOTION_SENSOR, INPUT);
    pinMode(IR_SENSOR, INPUT);
    pinMode(MICROWAVE_PRESENCE_SENSOR, INPUT);
    pinMode(WASHING_MACHINE_PRESENCE_SENSOR, INPUT);
    pinMode(MICROWAVE_THERMAL_SENSOR, INPUT);
    pinMode(WASHING_MACHINE_THERMAL_SENSOR, INPUT);
    pinMode(ROOM_THERMAL_SENSOR, INPUT);
    pinMode(KITCHEN_THERMAL_SENSOR, INPUT);
    pinMode(LIGHT_SENSOR, INPUT);
}

// Read sensor functions
// ...

// Main program
void setup() {
    Serial.begin(9600);
    // Initialize devices
    pinMode(ROOM_LIGHT, OUTPUT);
    pinMode(ROOM_FAN, OUTPUT);
    pinMode(KITCHEN_LIGHT, OUTPUT);
```

```
pinMode(KITCHEN_FAN, OUTPUT);
pinMode(MICROWAVE, OUTPUT);
pinMode(WASHING_MACHINE, OUTPUT);
pinMode(AC, OUTPUT);
pinMode(EXHAUST_FAN, OUTPUT);
pinMode(NIGHT_LAMP, OUTPUT);
// Initialize sensors
initialize_sensors();
}

void loop() {
  // Read sensors
  room_motion = read_motion_sensor(ROOM_MOTION_SENSOR);
  kitchen_motion = read_motion_sensor(KITCHEN_MOTION_SENSOR);
  ir_sensor = read_ir_sensor(IR_SENSOR);
  microwave_presence = read_presence_sensor(MICROWAVE_PRESENCE_SENSOR);
  microwave_thermal = read_thermal_sensor(MICROWAVE_THERMAL_SENSOR);
  washing_machine_presence = read_presence_sensor(WASHING_MACHINE_PRESENCE_SENSOR);
  washing_machine_thermal = read_thermal_sensor(WASHING_MACHINE_THERMAL_SENSOR);
  room_thermal = read_thermal_sensor(ROOM_THERMAL_SENSOR);
  kitchen_thermal = read_thermal_sensor(KITCHEN_THERMAL_SENSOR);
  light_intensity = read_light_sensor(LIGHT_SENSOR);

  // Perform actions based on sensor readings
  // ...
  delay(1000);
}
```

## 4. Results and Evaluation

### 4.1 Motion Detection and Illumination Regulation

The system effectively detected motion in the room and kitchen, activating the respective lights when motion was detected and the ambient light was insufficient. This feature improved energy efficiency by ensuring lights were only on when needed.

### 4.2 Fan Control Based on Temperature

The system managed room and kitchen temperatures by controlling fans based on predefined thermal thresholds. This regulation contributed to maintaining a comfortable environment and conserving energy.

### 4.3 IR Detection and Air Conditioning Control

IR signals from remote controls were detected by the system, which then activated the air conditioner to maintain a comfortable temperature. This feature ensured efficient air conditioning based on user activity.

### 4.4 Appliance Detection and Control

Microwave and washing machine usage were monitored through presence and thermal sensors. The system automated the activation of these appliances based on detected usage, maximizing efficiency.

#### 4.5 Night Lamp Management

The night lamp was controlled based on ambient light levels, providing gentle illumination when light intensity was low and reducing nighttime disturbances.

#### 4.6 Exhaust Fan Management

The exhaust fan was activated to remove excess heat when temperature thresholds were exceeded, enhancing ventilation and comfort.

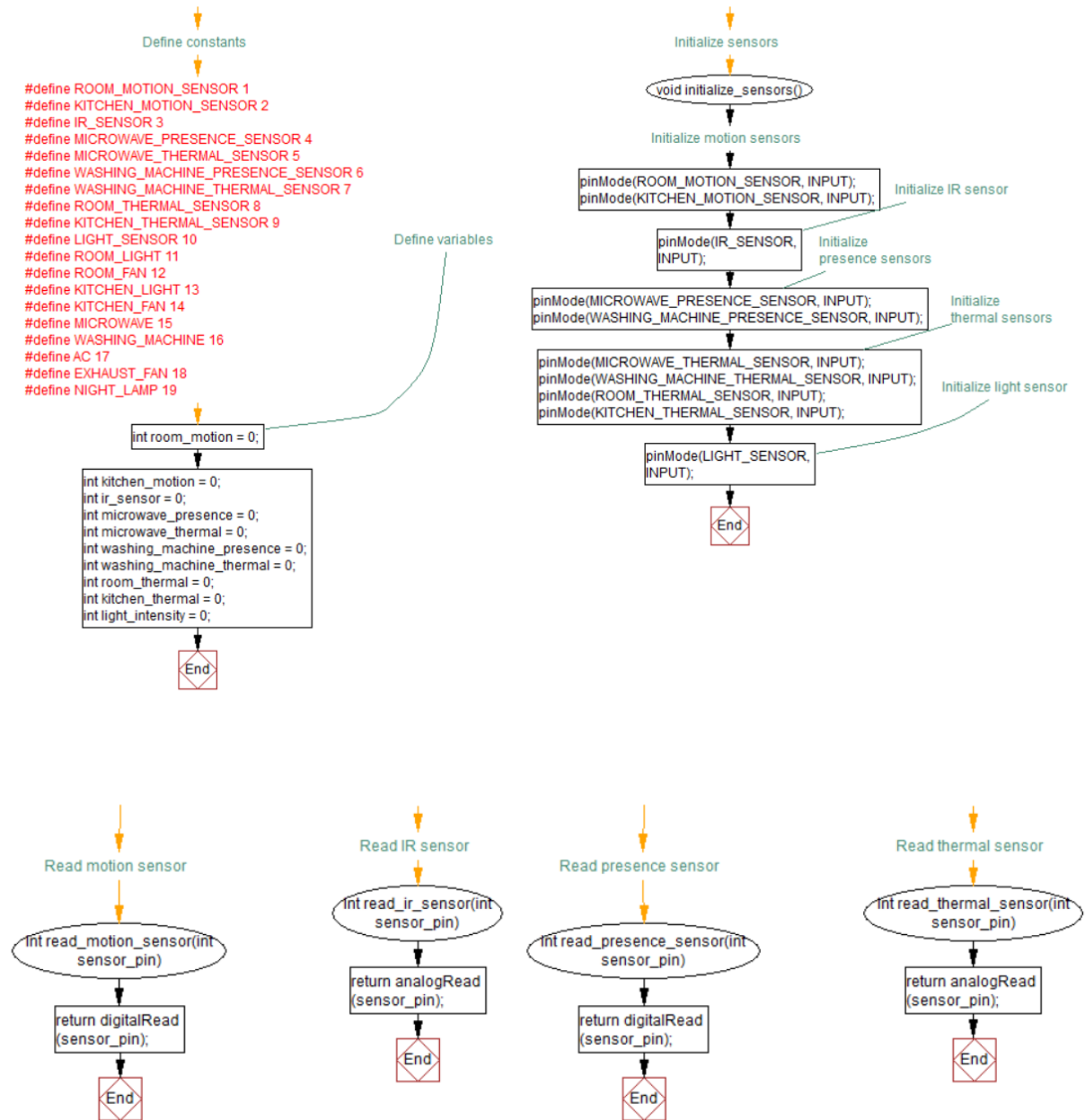

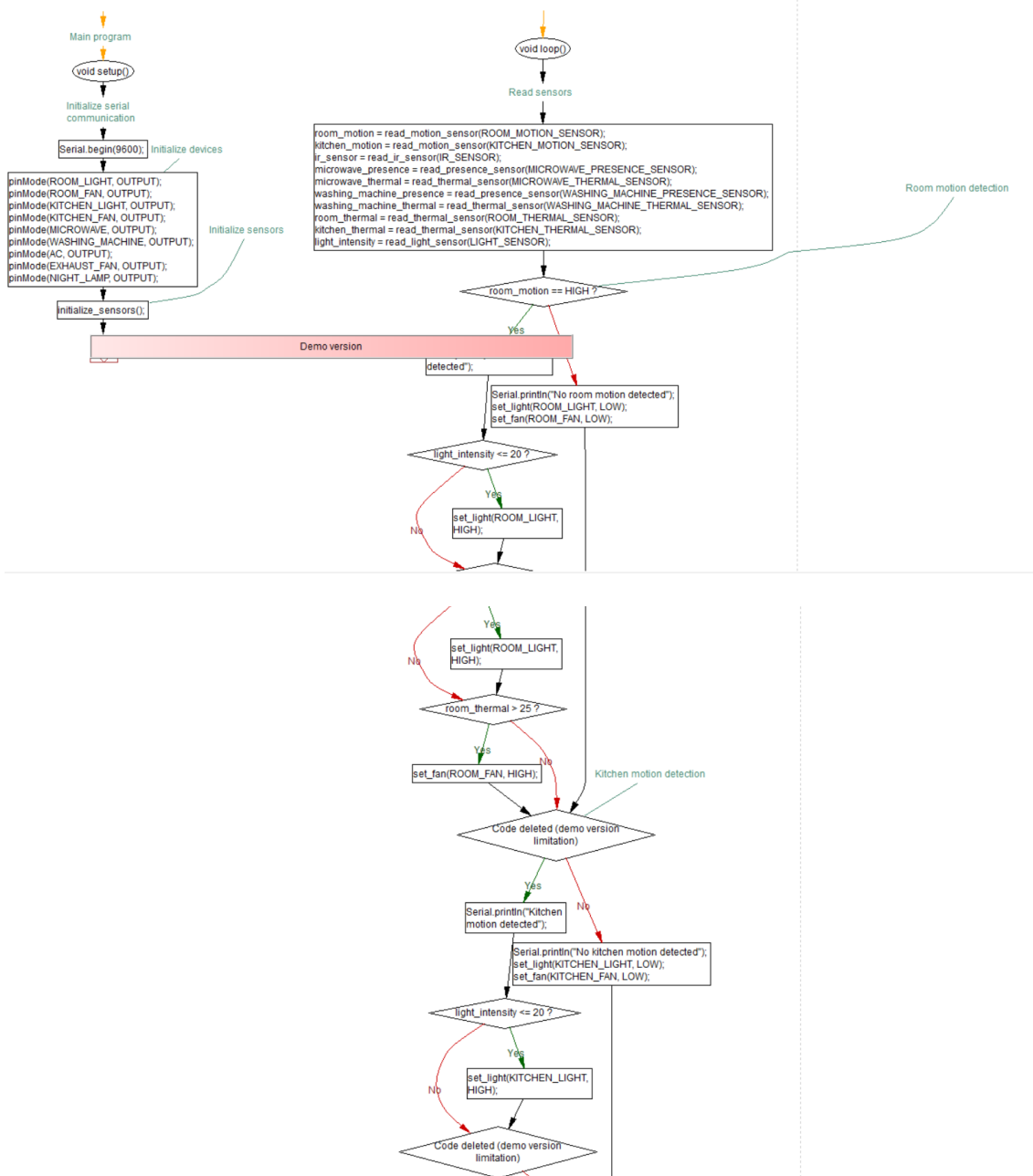
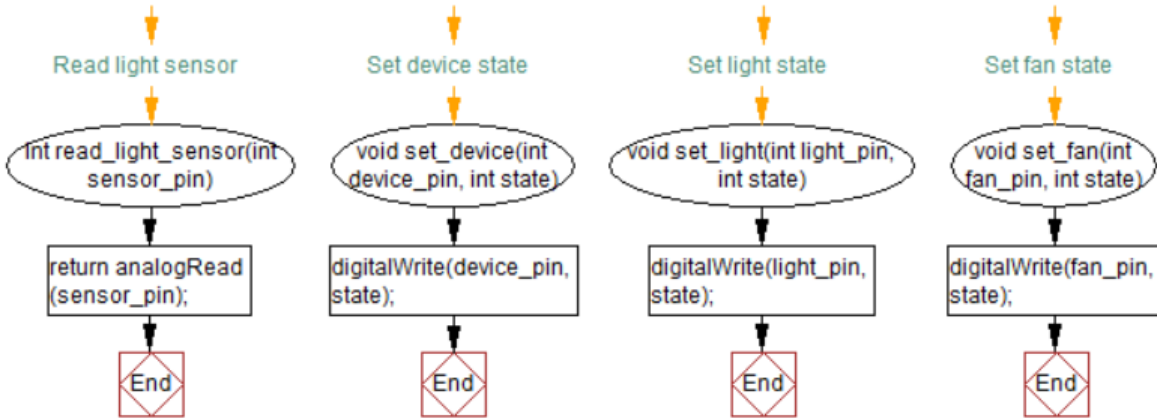

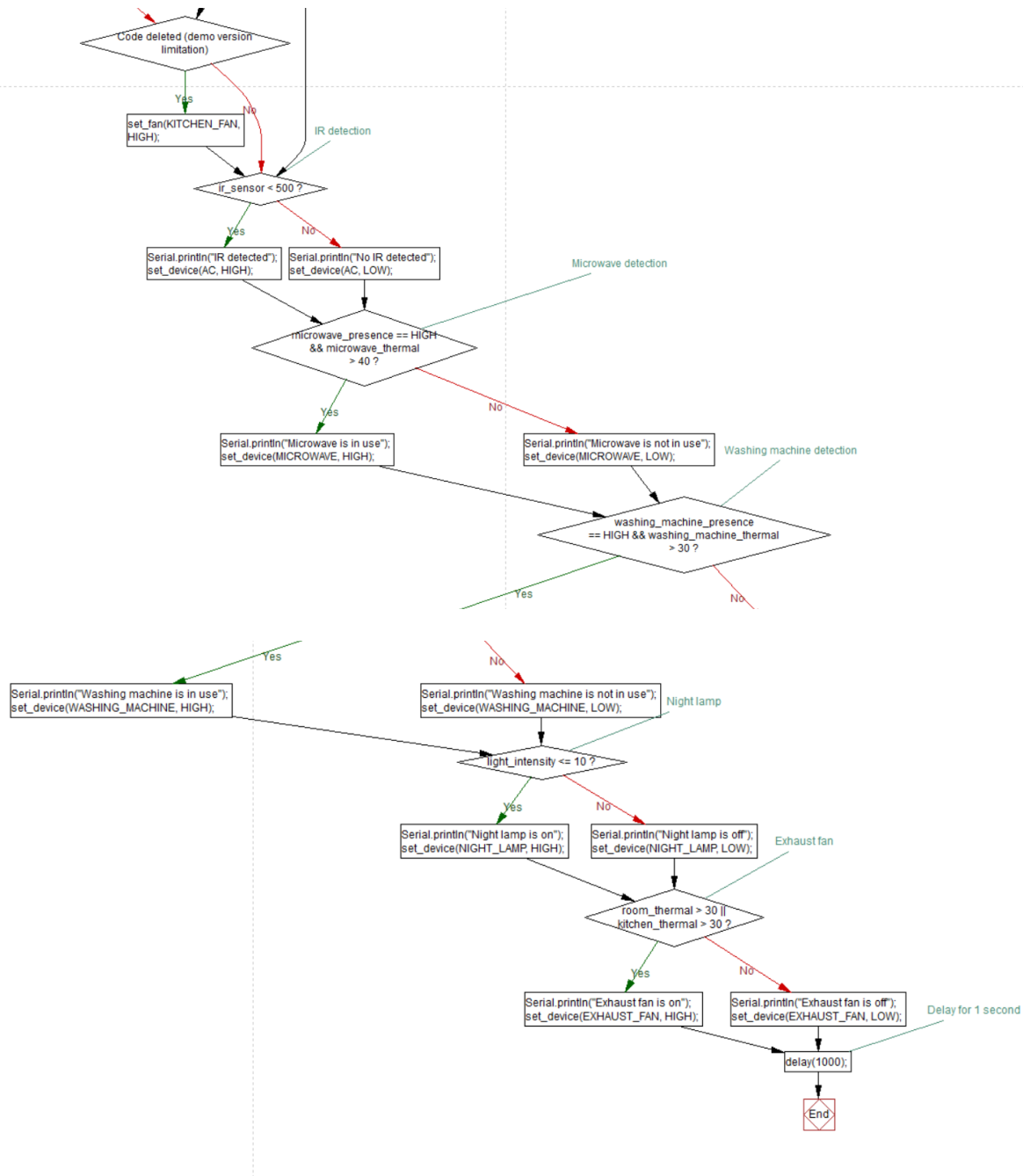

## 5. Discussion

The home automation system demonstrated effective integration of sensors and devices, achieving the goals of improved energy efficiency, comfort, and convenience. The modular design allowed for future expansion and integration of additional sensors. However, limitations such as sensor accuracy, limited automation features, and the lack of a user interface were identified.

## 6. Project Management

### *6.1 Planning*

Comprehensive planning involved requirement gathering, system design, and scheduling. The project team defined objectives, deliverables, and milestones for successful implementation.

### *6.2 Resource Allocation*

Resources included human capital (engineers, designers) and hardware/software components (sensors, microcontrollers). Effective allocation ensured smooth project execution.

### *6.3 Execution*

The project followed a structured approach for coding, integration, testing, and evaluation. Regular monitoring and quality control were performed to ensure system functionality.

### *6.4 Risk Management*

Risk management strategies were implemented to address potential threats. Regular assessments helped mitigate obstacles during project execution.

### *6.5 Documentation*

Comprehensive documentation of system specifications, design, and testing was maintained to ensure clarity and facilitate future modifications.

## **7. Conclusion**

### *7.1 Summary of Results*

The implemented home automation system effectively integrated sensors and devices to automate home functions, achieving improved energy efficiency, user comfort, and cost savings.

### *7.2 Contributions*

The research contributes to the field by demonstrating the feasibility of integrating diverse sensors for home automation, highlighting design considerations, and providing practical implementation examples.

### *7.3 Limitations and Future Work*

Future research should focus on scalability, integration with smart grids, improved user interfaces, and addressing security and privacy concerns.

### *7.4 Discussion*

The study provides valuable insights into home automation systems, with potential for further research and development to enhance residential living through advanced automation technologies.

## References

- [1] L. Atzori, A. Iera, and G. Morabito, "The internet of things: A survey," *Computer Networks*, vol. 54, no. 15, pp. 2787-2805, 2010.
- [2] H. Chen, C. D. Nugent, H. Wang, and M. Wang, "A survey of smart home applications," *J. Ambient Intell. Smart Environ.*, vol. 2, no. 4, pp. 309-327, 2010.
- [3] T. A. R. H. Shuja, R. Kumar, and A. S. Q. Omar, "Design and implementation of home automation system based on Arduino and mobile communication," *Int. J. Eng. Tech.*, vol. 9, no. 4, pp. 2795-2803, 2017.
- [4] S. K. Sharma and S. Sharma, "A survey on home automation technologies," *Procedia Comput. Sci.*, vol. 132, pp. 454-461, 2018.
- [5] A. K. M. S. Arif, S. Ali, and N. K. Choudhury, "An overview of home automation system with sensor integration," *IEEE Access*, vol. 8, pp. 105370-105381, 2020.