

SMART SOLAR POWER INVERTER

Sheeja NAIR^{1,*}, Janvhi JAIN¹ and Muskaan Fatema KHUNT¹

¹*Dwarkadas J Sanghvi College of Engineering, Mumbai, Maharashtra, India*

Abstract. *The growth of the solar market over the past few years has been remarkable, with the increase in total number of installations of photovoltaic plants worldwide. The impact of this ever growing clean and efficient renewable energy generation makes it imperative that the grid infrastructure become more resilient and smart to produce uninterrupted flow of electricity. The research paper focuses on two main aspects viz. generation of electricity through solar energy and secondly connecting wireless communications to monitor the solar power inverter. The solar based inverter circuit along with Internet of Things (IoT) interfaced level indicator circuit. To indicate the amount of charge left and time consumption depending upon different load usage IoT devices are used to monitor.*

Keywords: Solar power systems, inverters, photovoltaic, Internet of things (IoT).

1. Introduction

Air pollution due to carbon emission is a perennial problem faced globally causing a big threat to the environment and health in particular. Thus it becomes essential to explore energy resources which have least carbon content. Renewable energy resources have been widely acknowledged as a viable option to override this issue. Use of solar power will expand dramatically. Globally the overall power consumption, 17 percent was directly generated from solar energy for the year 2017. 26.2 percent of energy was generated using solar energy in 2018 worldwide; which will soon penetrate to 45 percent by 2040 [1]. The most common usage of solar energy is to convert the sun rays into usable electricity. To form a photovoltaic (PV) module, the solar cells are connected in series [2]. To vary the voltage and frequency, the appropriate use of transformer, control and switching circuits are used. Inverters are used in a wide range of applications, from small switching power supplies in computers to large applications to transport huge power. The residential solar inverter is the one which produces utility frequency alternating current from direct current of the photovoltaic (PV) solar panels.

The internet has significantly changed the way most electronic systems are designed. From small scale applications to complex industrial systems, all are now using connectivity as a significant part of their functionality. The introduction of sensor systems along with IoT that collect data and pass the information to the cloud, these range from temperature monitoring, heating control, level of battery charged in inverter, utility time consumption etc.

2. Design Technique

The proposed paper involves two main areas. First is power electronics where solar power inverters are used to generate alternating current. It consists of different components like photovoltaic cell, battery, inverter, filter circuits and other electrical components which convert direct solar or battery based electricity into alternating current which can be used for domestic home appliances or industry [3].

Secondly smart solar inverter is used for wireless data communication with reference to all the various parameters related to the inverter like power usage and time consumption with different load activation. For this functionality devices like arduino controller, ESP8266 wifi module, crystal oscillator, lcd and so on are incorporated. These are used to provide comfortable and effortless output to the user about inverter operating time, load consumption, battery used etc.

3. Solar Power Inverter

When there is sufficient solar energy, the inverter is used to convert the solar energy to the load directly. When there is insufficient solar energy, the inverter will use the battery to supply power to the load. When the sun's rays interact with the photovoltaic system, electrons begin to move, producing direct current. Solar power systems are one of the power systems where solar energy absorbed by solar panels is converted to direct current. The home appliances majorly work on single phase ac supply [4]. To produce ac supply, a solar inverter is used which converts variable dc output of a photovoltaic solar panel into alternating current. This ac electricity then can be fed into your home to operate your appliances. The excess electricity can be fed into the grid (electrical power lines) or into home battery storage. Fig.1-Inverter block diagram.

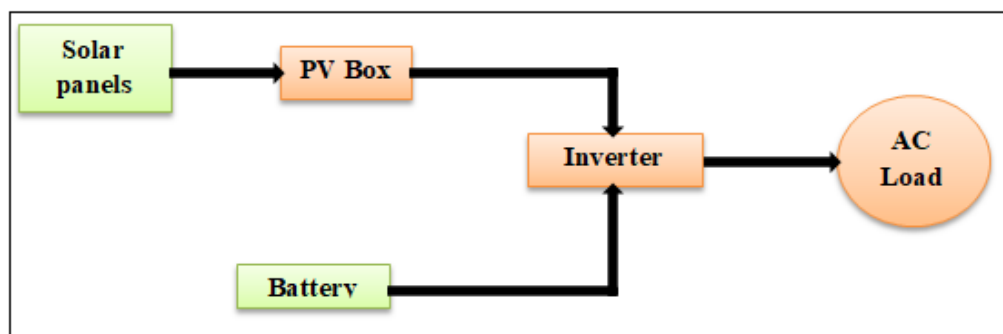

Fig.1-Inverter block diagram

4. Internet of Things (IoT) interfacing with Solar Inverter:

To make the solar inverter more user friendly wireless technology is added in the traditional circuit. There are different wireless technologies available like Zigbee, Wifi, Bluetooth, GSM, etc. Wifi can be easily considered as it's cheap and very adaptable for home automation. The devices like computers, tablets and phones can be easily connected with wifi and can be easily monitored. However, any two hardware components can be connected together using wireless technologies [5].

4.1. Working of IoT with Solar Inverter

The necessity of renewable energy sources, mainly solar, is increasing day by day. It is interfaced with the battery such that uninterrupted supply is fed. Sensors are used to measure and transfer current and voltage values to the inverter which is interfaced with the filter to obtain pure sine waves.

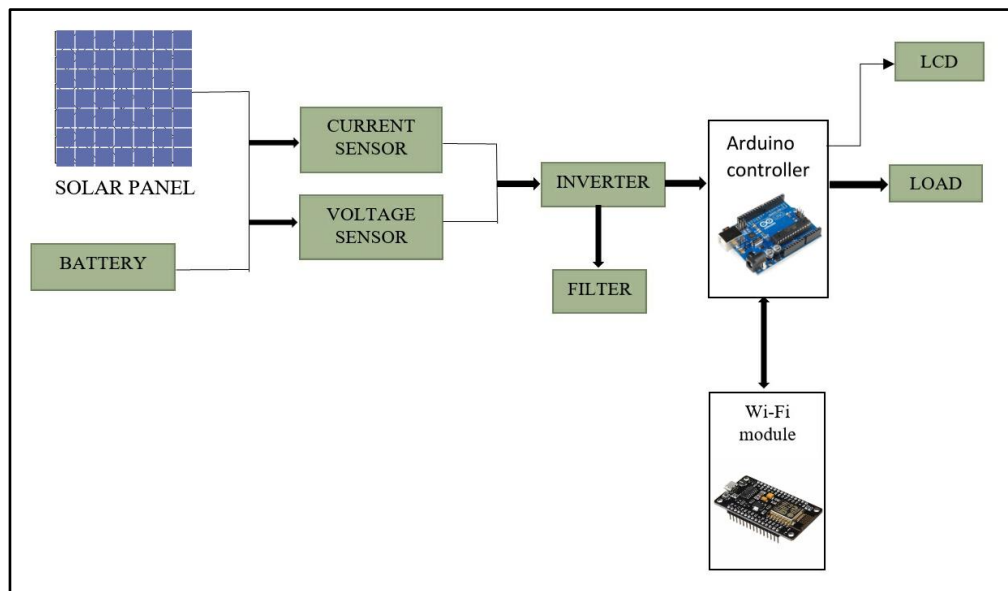

Fig.2. IoT based solar power inverter

The analog signal is fed to the arduino uno board which will communicate with load as well as wifi module and pass the information to the user through wireless communication. Fig.2- IoT based solar power inverter.

4.2. Main Components

A solar inverter converts the dc output of a PV solar panel into a useful ac that can be fed into a commercial electrical grid or domestic appliances. During peak hours solar energy is directly used to generate electrical energy to run load along with its battery and can also be stored. Fig.3- Variation in irradiance. This energy is stored in batteries during peak hours [6]. The proposed system is designed to utilize maximum solar energy for home loads using an inverter. The schematic diagram of a smart solar inverter consists of ldr, crystal oscillator, battery, current sensor, filter circuit, arduino uno controller and lcd (liquid-crystal display). To represent the intensity of solar energy which is constantly varying, ldr is used. Light dependent resistors (LDRs) consist of resistors whose values depend upon the intensity of the light. As the intensity of light falling on the ldr increases, resistance value decreases which increases the flow of current and vice-versa [7].

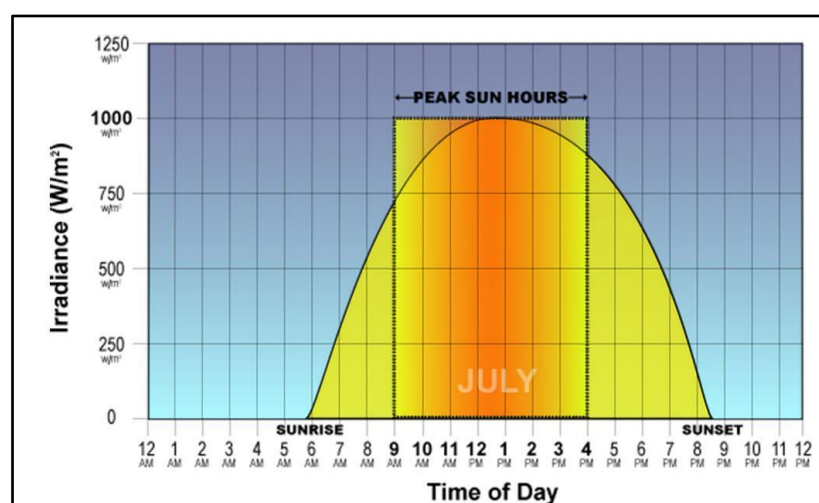

Fig.3-Variation in irradiance

DHT sensors along with external crystal oscillators are included to measure the humidity and temperature of the solar energy. It is fed to the analog signal of the arduino controller board. Alternatively, the battery is connected which gets activated when solar power is least available. Battery is connected to the current sensor as well as voltage sensor. The voltage and current can be varied using an external potentiometer. It is also connected to the analog signal of the arduino uno controller. It can also be controlled using a wifi module.

4.3 Arduino controller:

Arduino is a microcontroller-based open source electronic prototyping board which can be customized with a simple to-utilize arduino IDE [8]. It consists of six analog pins from A0 to A5 and 14 digital pins from 0 to 13. The digital pins can be used as input as well as output. Also, it consists of a 5V supply and ground pin. According to the system requirements as well as components' needs, the arduino family was chosen as they offer the highest degree of integration with greater ease, reliability and being economical. The lcd is connected to the digital pins of the arduino uno board which will display the output. Fig.4 - Schematic diagram of smart solar inverter.



Fig .4. Schematic diagram of smart solar inverter

5. Results

5.1. MATLAB/SIMULINK

It is used to execute the solar power inverter and pure single phase sine wave is obtained. The solar energy is converted to alternating current for domestic appliances. The circuit diagram consists of the solar panel, inverter circuit, filter etc. In the PV array, the Irradiation is set to 1500 Watts/m square and temperature is set to 25⁰ C as inputs. The capacitor is then connected at the output end of the PV array to store the energy. The capacitor is further connected to the universal bridge (MOSFET/Diodes) which converts dc to pure ac signals. The arms are connected to a passive filter i.e. inductor and capacitor in series and the resistor in parallel to the capacitor. Fig.5- Single phase solar power inverter using MATLAB/SIMULINK.

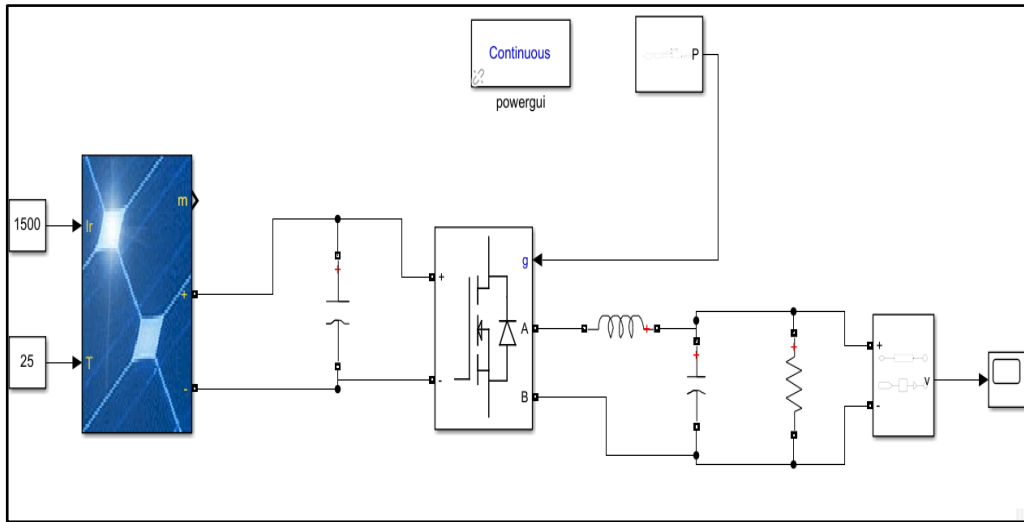

Fig.5 Single phase solar power inverter using MATLAB/SIMULINK

The voltage measurement is set across the resistor which is further connected to the scope to see the graph of the output voltage. Thus it is observed that we get a sinusoidal wave, indicating the dc being converted to ac. Fig.6- Output sine waveform.

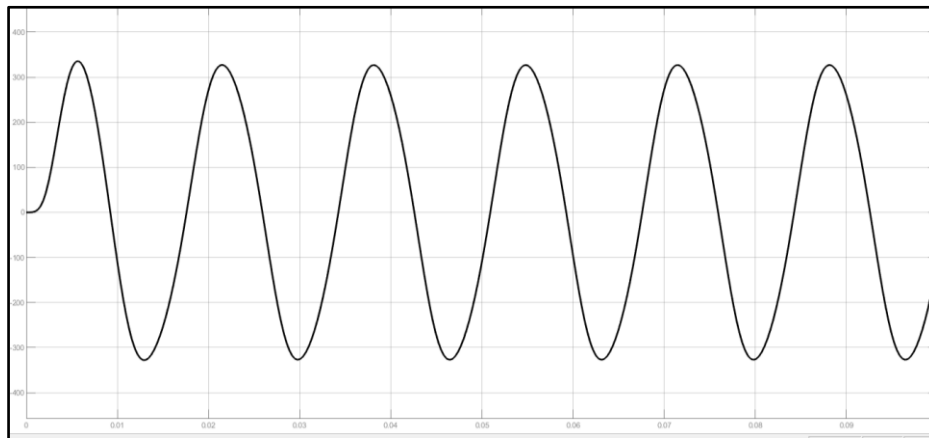

Fig.6. Output sine waveform

A flow chart indicates the step by step process. When solar energy is maximum V_{sol} greater than or equal to V_{set} voltage which is 12V then it is given to the load as well as to charge the battery.

When solar rays are least available then dc supply is fed from the battery to the inverter and filter circuit is used which converts pulsating waveform into pure ac to run this load. Fig.7 -Flowchart representing basic Power Inverter.

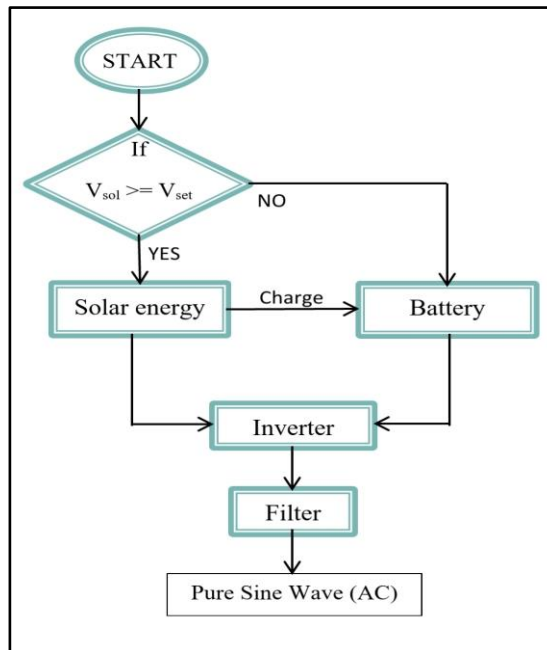

Fig.7- Flowchart representing basic Power Inverter

Solar tracking power MOSFET inverter

The simulation was executed in Proteus using two light dependent resistors (LDR) which indicates the ambient intensity of solar light power MOSFET is connected which makes an h-bridge circuit. When 12V dc supply is applied then it is observed that ac output is obtained. Fig.8- Solar tracking power MOSFET inverter.

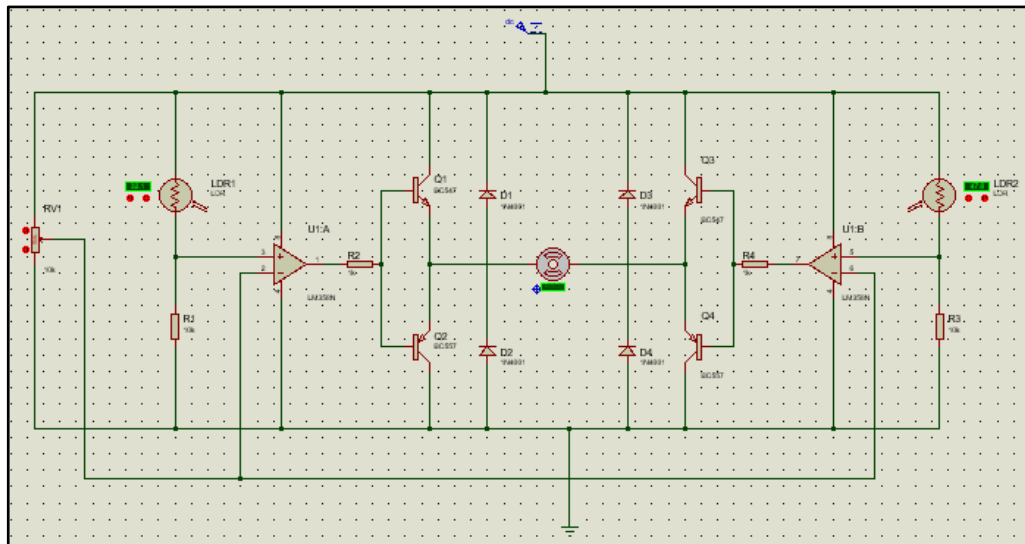

Fig 8. Solar tracking power MOSFET inverter

The speed of the motor can be controlled by increasing the ldr intensity. To provide constant voltage, an operational amplifier is used. Fig.9- input and output waveforms indicates the input and output waveform obtained. When 12V dc is applied, the output obtained is 237.50V ac as indicated in the digital oscilloscope.

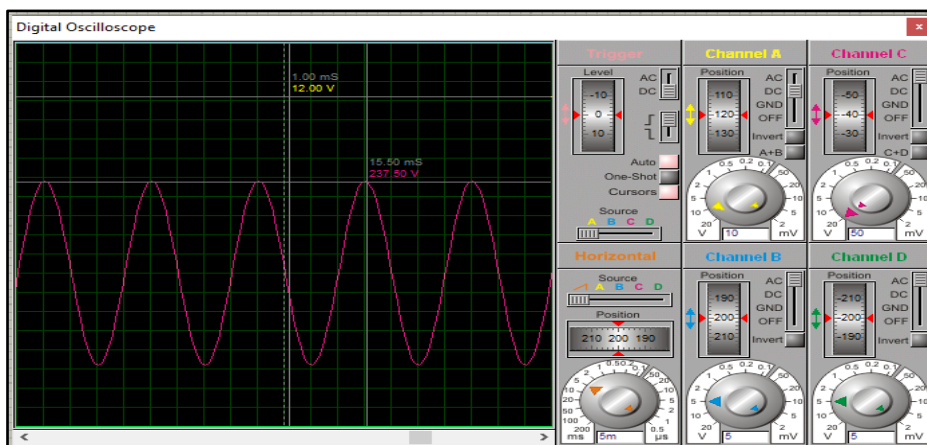

Fig .9- Input and Output Waveforms

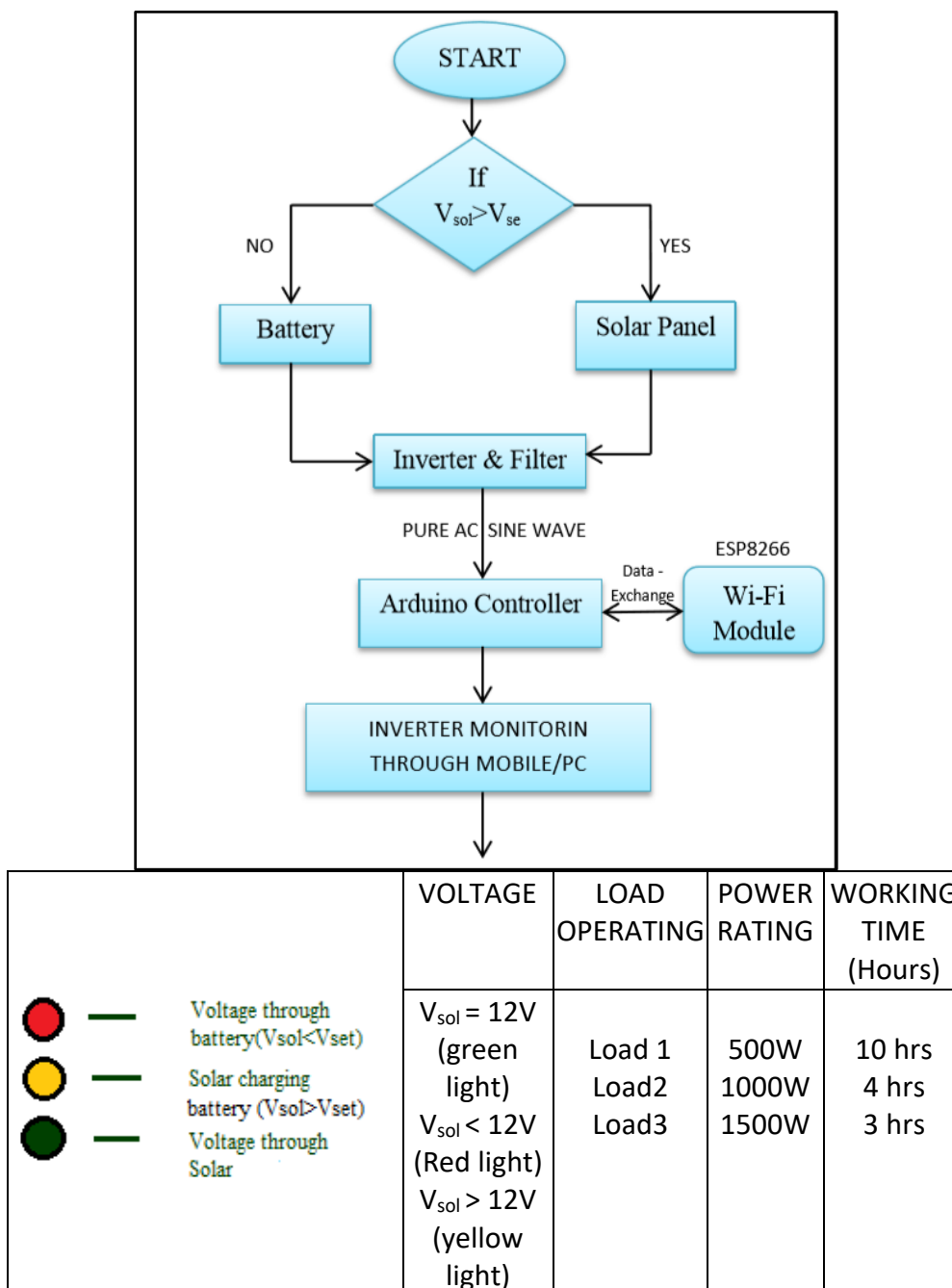

Fig.10- Smart solar monitoring system

The flow chart of a smart solar monitoring system is explained. Fig.10- Smart solar monitoring system. The analog signal is passed to the arduino controller board which is interfaced with the wifi module to provide timely updates to the user through smart phone devices. Above table indicates the display to the user. Red light indicates that the solar voltage is less than 12V and dc voltage is fed to the inverter through the battery. If solar voltage is greater than 12V then it charges the battery and inverter. If voltage is equal to 12V it can just give a signal to the inverter. If voltage is less than 12V then the supply isn't capable of running the load. For different power ratings the work hour varies. As we increase the number of loads as well as the power ratings, the working hours will reduce accordingly.

6. Analysis

A survey was conducted to know about the awareness of people on solar power systems and their opinions on the deployment of solar power systems mentioned in Table 1.

Table 1. Survey of Opinions of People on Solar Power Systems

Qt. No.	QUESTIONS	Strongly Agree%	Agree%	Disagree%	Strongly Disagree%
1	Solar energy is an alternative power source from sunlight.	83.60%	11.50%	0%	4.90%
2	Many people are not aware of solar energy as an alternative power source.	21.30%	32.80%	39.30%	6.60%
3	Solar energy equipment is not easily acquired.	24.60%	41.00%	26.20%	8%
4	Organizations should include alternative power source in their maintenance policy	62.30%	21.30%	13.10%	3%
5	The economic advantage of Solar Energy deployment as an alternative power source is greater than installation cost.	49.20%	26.20%	19.70%	4.90%

The survey conducted among 65 people included students (65 to 70%), professionals (15 to 20%), and residents (15 to 20%). Fig.12- Response in survey conducted.

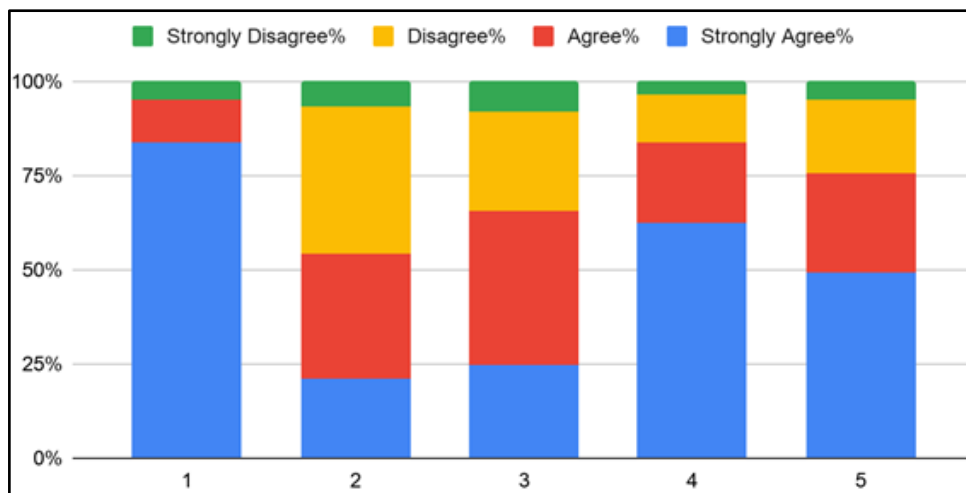

Fig.12- Response in survey conducted

Based on the responses, it is seen that all people know about the existence of solar energy. However, they aren't much aware of its applications or how to approach it. But when asked about opinions, many people are inclined towards the idea of going solar. Thus effective measures should be taken to educate people about the details of the solar power systems so as to enable sustainable lifestyle and a beautiful Earth for the future generations.

There are a reasonable number of people who haven't witnessed the applications of solar energy which does indicate the lack of implementations. Since the paper is slightly inclined towards the small scale domestic use of the solar power systems, the use of Micro Inverters is most advisable. Although they are expensive, they are the best to opt for single or few panel systems. Fig.13- Overall response.

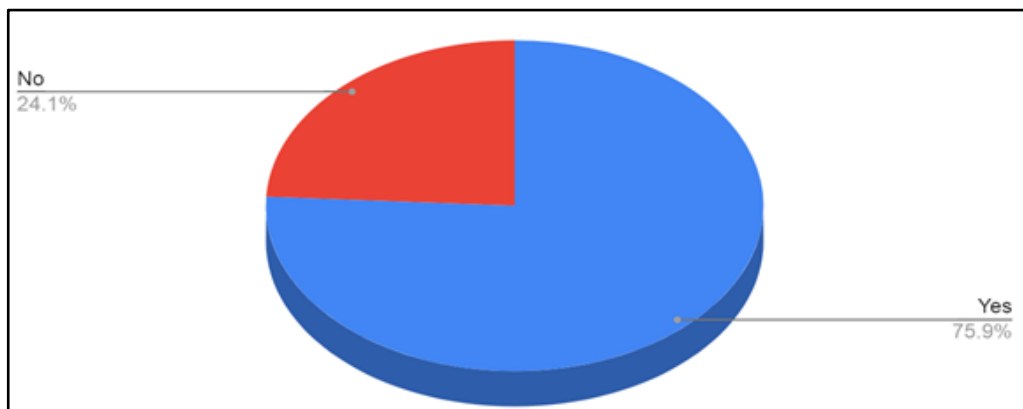

Fig.13- Overall response

7. Advantages

Benefits associated with smart grid include:

- More efficient transmission and distribution of electricity.
- Quicker restoration of electricity after power outages.
- Increased and efficient integration of variable renewable energy systems [9].

The durability of digital inverter compressors is high as compared to that of reciprocal compressors thereby reduction in the wear and tear of the compressor. Another main advantage of smart inverters is their ability to produce grid-matching power at the level of a single solar panel. Each solar panel has its own smart inverter; solar panel arrays are connected in a parallel connection configuration and then connected to the power grid because of Iot integrated system, the system can be analysed and faulty components can be recognized remotely in real time.

8. Conclusion

The sun being the supreme power, everyone has limitless access to its energy. Hence, harvesting this unlimited resource of energy shall make us independent of energy to some extent. Going the solar way shall not take much to start with initially, atleast at a micro level, this would save and put less pressure on the power grids and reduce power consumption bills. The said solar energy can be harnessed with the help of inverters and can be economically available to every household. This would also reduce the dependence on fossil fuel energy which is non-renewable and also has higher carbon emissions.

The overall research focuses on how we can have an optimum utilization of solar based power inverters in terms of harnessing solar power through these inverters and give an real-time update on

any smartphones with regard to power update, battery levels, remaining charge time left, time to full charge, switching of power input to batteries from solar power for domestic power in the absence of sufficient solar energy.

REFERENCES

- [1] Solar power energy/<https://www.c2es.org/content/renewable-energy/>
- [2] Vaishali T. Tekade¹, Mrunali R.Kude², Bharat D.Deore³, Priyanka V. Ahire⁴, “Design and development of solar panel inverter with MPPT. International and research journal of engineering and technology. Vol: 04/ April-2017.
- [3] Bal Bheem Nadpurohit¹, Roopa Kulkarni², Kadappa Manager³, Nagaraj Devar⁴, Rahul Karnawadi⁵, Edmund Carvalho⁶, “IoT Enabled Smart Solar PV System”, International Journal of Innovative Research in Computer and Communication Engineering. Vol. 5, Issue 6, June 2017.
- [4] Megha A Joshi¹, Kavyashree S², “IOT Based Smart Inverter Using Raspberry PI”, International Journal of Latest Technology in Engineering, Management & Applied Science (IJLTEMAS), Volume VI, Issue VS, May 2017 | ISSN 2278-2540.
- [5] Ninganagouda Biradar¹, Dr. Baswaraj Gadgay², Veeresh Pujari³, “An IOT Enabled Smart Inverter”. International Journal for Research in Applied Science & Engineering Technology IJRASET, Volume 5 Issue VI, June 2017.
- [6] Solar energy.<https://www.solarreviews.com/blog/peak-sun-hours-explained>.
- [7] Sun track device. <https://www.electronicshub.org/sun-tracking-solar-panel/>.
- [8] Arduino board/ <https://machirurgie-esthetique.com/chapter-1/>
- [9] Smart Grid, Smart Inverters for a Smart Energy Future <https://www.nrel.gov/state-local-tribal/blog/posts/smart-grid-smart-inverters-for-a-smart-energy-future.html>