

Volume characterisation of the electrical discharge

Cristian Victor Lungu, Bogdan Hnatiuc

University “Dunarea de jos” from Galati
Maritime University Constanta
Cristian.lungu@ugal.ro

Abstract. In this paper, theoretical and practical study of gliding arc discharges is presented considering the discharge itself. The characteristics of the gliding arc are studied at different flow rate values. For this study case instrumental air was used in order to elongate the spark thus obtaining the gliding arc. The comparison took into consideration linear approximations of the discharge compared to the real phenomena.

1. Introduction

Generally, plasma can be broadly classified into various categories: Non- equilibrium or non-thermal, equilibrium or thermal and transitional plasmas. The step-by-step processes of ionization and dissociation occur through huge amounts of energy or heat addition. As a result of the heat addition, the gas temperature becomes very high in the range of 5000 K to 50000 K, with the temperature of the electrons in the same order and energy input in all degrees of freedom. From the point of view of ignition, it is not necessary for the gas to have such a high temperature,[1].

Non-thermal plasmas are conventionally generated in low pressures and have high chemical selectivity and the capability of homogeneous activation, [1].

An ideal plasma discharge should have intermediate temperatures between the temperatures of non-equilibrium and equilibrium plasmas. A gliding arc discharge is a unique type of non-thermal plasma that has a relatively high plasma density, a high electron temperature, relatively low gas temperatures that is less than 3000 K, power and operating pressure in comparison with other non-thermal discharges, and good chemical selectivity in comparison with equilibrium discharges. Also, the gas temperature of some species is still high enough to speed up the interaction between the neutral species, [2].

Gliding Arc discharges are described as a typical source of low-temperature plasma because of their non-thermal attributes [3]. A gliding arc is a string-like plasma column that ignites repeatedly in the narrowest gap between two diverging electrodes. It can also be described as a plasma column that extends between two diverging electrodes along the direction of a turbulent gas flow. It glides along the electrodes and extinguishes as it re-ignites at the shortest gap.

As the ignition of a new plasma column occurs, the previous plasma column extinguishes. During the ignition stage, the plasma temperature is high but the ions are swiftly cooled and a non-equilibrium condition is created.

In the transitional regime, the discharge starts like a thermal arc and during its evolution it evolves to a glow discharge. This permits to achieve the non-thermal plasma conditions that are essential for operation,[1].

The elongating arc demands more power to sustain itself, until it reaches the maximum that the power supply can provide. However, due to continuous gas flow, the length of the arc continues to grow but the power supplied by the source is not enough to balance the energy losses to the

surrounding gas. If the power supply is capable of providing sufficiently high voltage, the arc changes its ionization mechanism to a non-thermal one. Because of instability, the arc cools down and finally extinguishes, marking the end of one cycle.

2. Linear approximation of the Glid Arc discharge

For the approximation of the discharge, the shape considered is a circle segment; however a small discharge space was taken into account, thus the area of the Glid Arc discharge surface is:

$$S = \frac{\pi r^2 n^\circ}{360^\circ} - \frac{x \cdot h}{2} = 1137,3 \text{ mm}^2 \quad (1)$$

Considering the width of the discharge of 5mm, the volume of the discharge is calculated as:

$$V = S \cdot W = 5762,5 \text{ mm}^3 \quad (2)$$

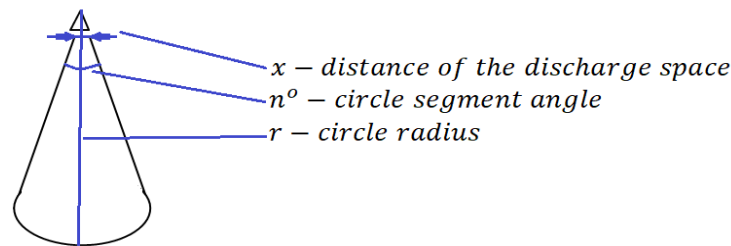

Figure 1. Discharge approximation drawing for calculating the volume

Considering a linear approximation of the combination and recombination phenomena, the discharge volume evolves according to Figures 2, 3 and 4.

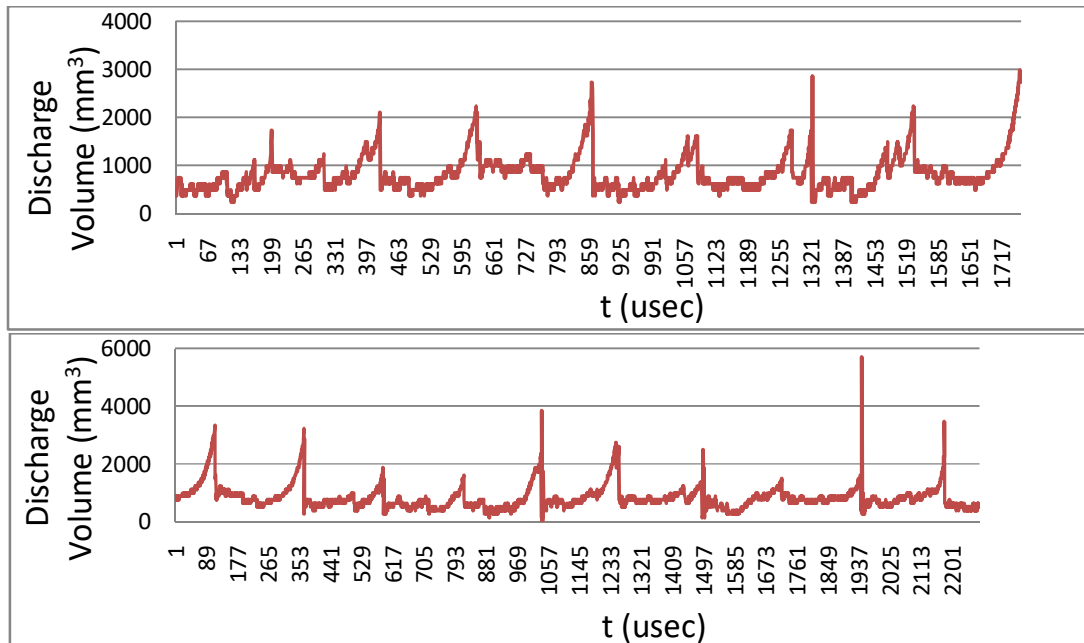

Figure 2. Linear approximation of the discharge volume at a flow rate of 5 l/min

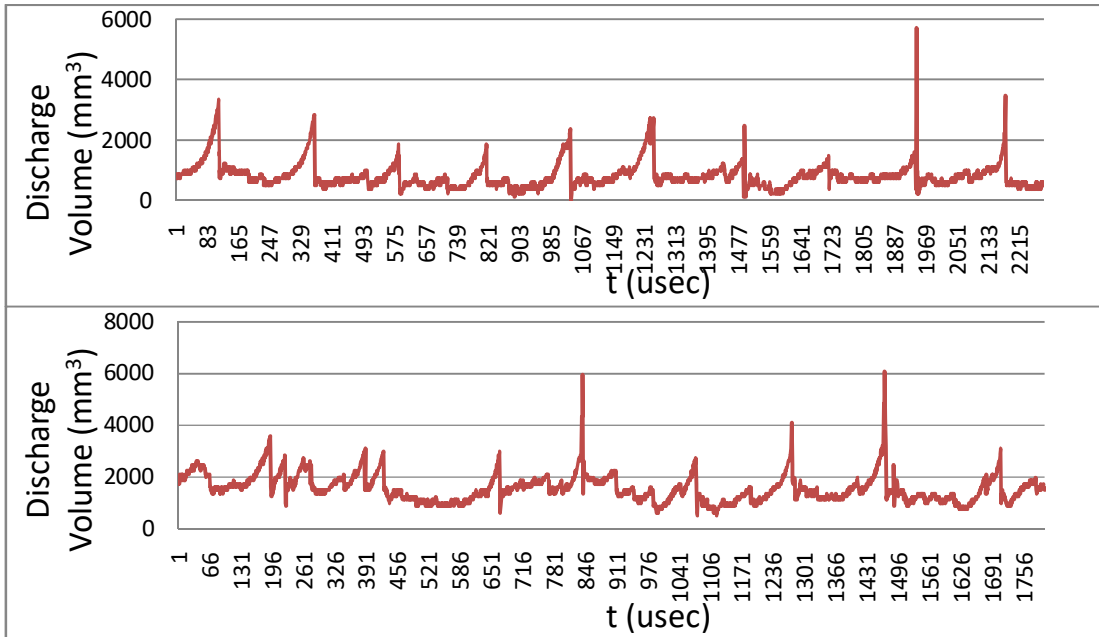

Figure 3. Linear approximation of the discharge volume at a flow rate of 10 l/min

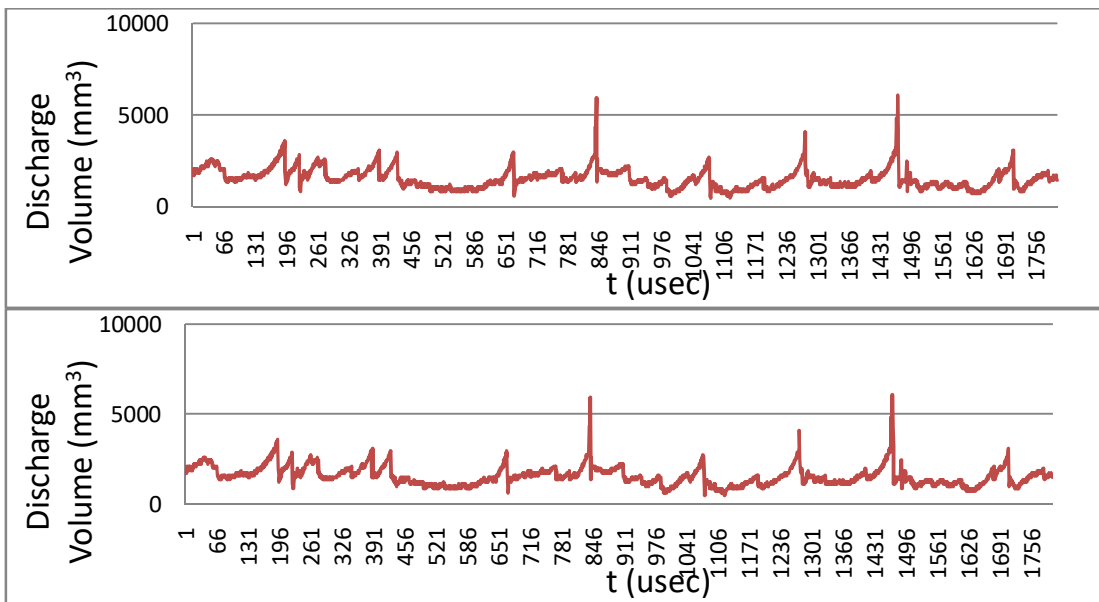

Figure 4. Linear approximation of the discharge volume at a flow rate of 15 l/min

Each figure contains 2 graphs that were obtain in similar manners. Considering that the actual discharge depends of parameters such as the gas flow rate, the inter-electrode gap, length of the arc and the time of evolution. The Figures 2, 3 and 4 show the evolution of the discharge consistent with the voltage variations and different flow rates. For Figure 2 the flow rate used was 5 l/min, for Figure 3 the flow rate used was 10 l/min and for Figure 4 the flow rate used was 15l/min.

3. Dynamic evolution of the Glid Arc discharge

The measured electrical parameters are used to calculate the velocity of the arc which is compared to the velocity of the gas. Therefore, precise measurement of the length of the arc is necessary.

In the transitional regime, the discharge starts like a thermal arc. Initially, the discharge has a character of an electric arc however during its transition it evolves to a glow discharge. This permits to achieve the non-thermal plasma conditions that are essential for operation of the described reactor with non –thermal plasmas, [3].

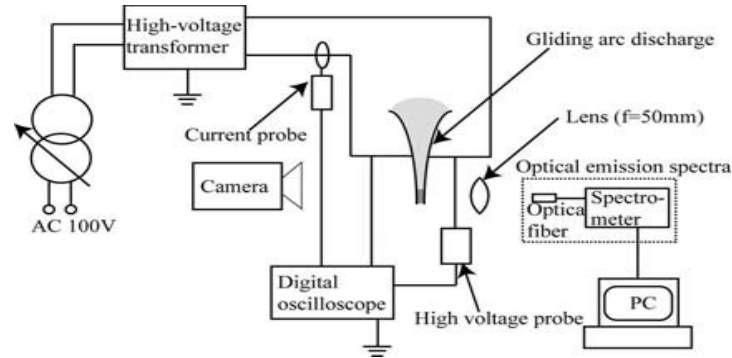

Figure 5. Experimental setup

In Figure 6 presented below shows the gliding arc discharge captured by the 1000fps high-speed camera at different gas flowrates. The pictures were obtained by converting the video footage of the experiment into 20 frames. By calculation, it means that the time interval between each frame is one millisecond.

Initial real length of the arc or the inter-electrode distance $l_0 = 2$ [mm]

Initial measured length of the arc $l_{i0} = 10.23$ [mm]

Measured length of the arc l_{mi} [mm], where i is the frame number

The calculated length of the arc is given by: $l_{ci} = \left[\frac{l_0 * l_{mi}}{l_{i0}} \right] * 0.001$ [m] (3)

The velocity of the discharged arc is: $v_{di} = \frac{l_{ci}}{t}$ [m/s] (4)

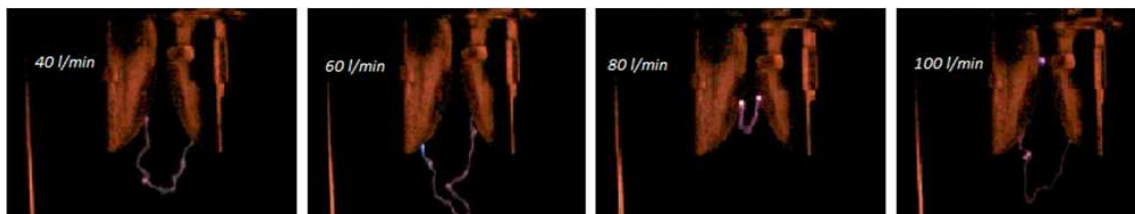

Figure 6. Arc flowrates at 40 l/min, 60 l/min, 80 l/min and 100 l/min

A high-speed camera of 1000 frames per second (1000 fps) was used to capture and record a video of the motion of the gliding arc. The camera recorded separately the motion of the plasma at the following gas volumetric flowrates of 40 l/min, 60 l/min, 80 l/min and 100 l/min.

In Figures 5, 6, 7 and 8 the plasma arc length variation is presented for flowrates of 40 l/min, 60 l/min, 80 l/min, 100 l/min.

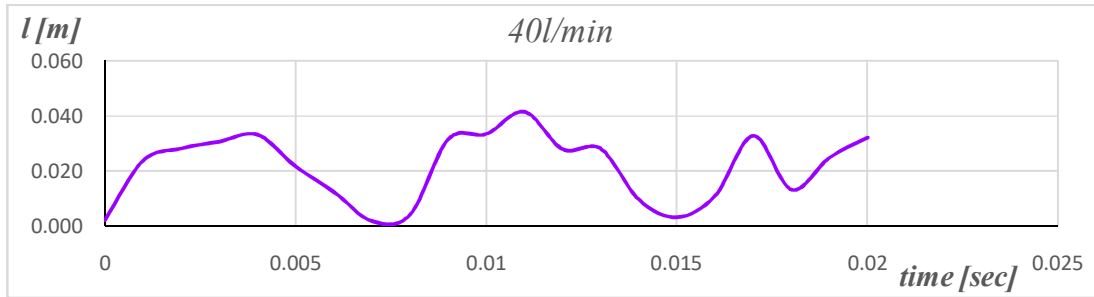

Figure 7. Plasma arc variation of length at 40 l/min

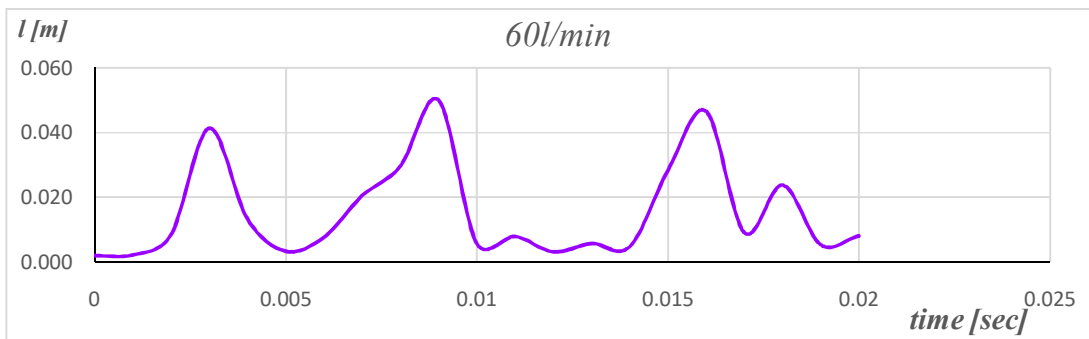

Figure 8. Plasma arc variation of length at 60 l/min

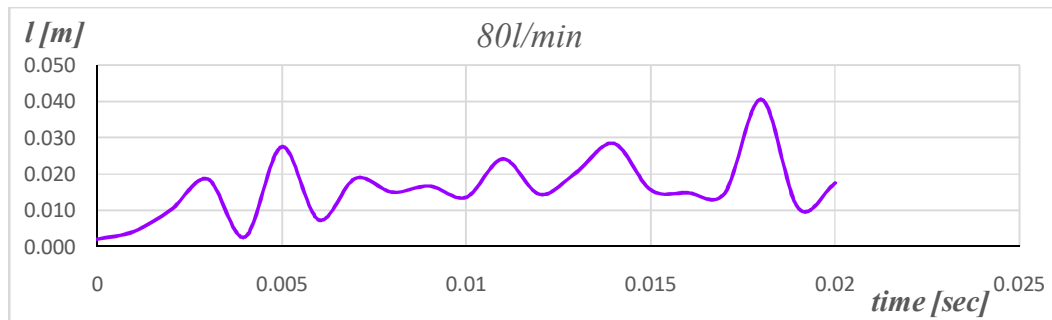

Figure 9. Plasma arc variation of length at 80 l/min

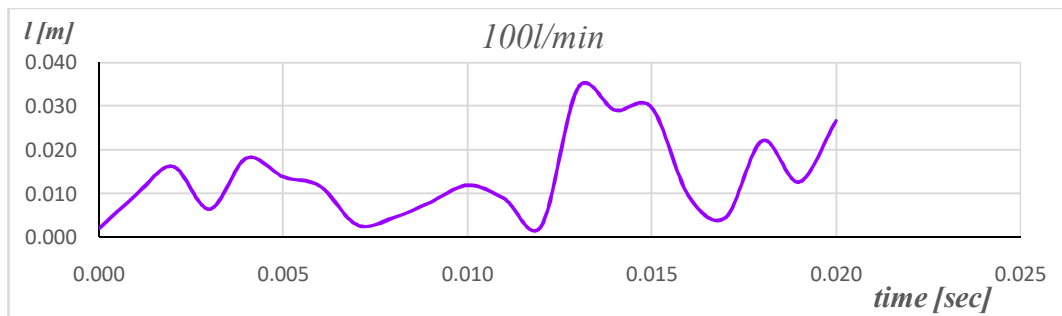

Figure 10. Plasma arc variation of length at 100 l/min

4. Conclusion

The parametric study shows that, from a qualitative point of view, the increase of the current raises the electrode hotspot size. Video images analysis shows that the evolution of the arc depend on voltage, current and gas flow.

Compared to the approximation used, the results are strongly non linear, as it was expected, considering Panchen's law and electron – ion recombination.

The combination of the gliding arc, elevated temperatures, and the precondition of no flame, before ignition, would allow for an ideal platform to observe the effect of ignition enhancement.

References

- [1] A. Fridman, "Characteristics of Gliding Arc and Its Application in Combustion Enhancement," *Journal of Propulsion And Power*, Vols. Vol. 24, No. 6, no. DOI: 10.2514/1.24795, p. 4, 2008.
- [2] A. Fridman, "Characteristics of Gliding Arc and Its Application in Combustion Enhancement," *JOURNAL OF PROPULSION AND POWER* , Vols. Vol. 24, No. 6, no. DOI: 10.2514/1.24795, p. 3, 2008.
- [3] S. Pellerin, F.-P. Richard, J Chapelle, J-M Cormier, Karol Musoil, "Heat string model of bi-dimensional dc Glidarc," *Journal of Physics D Applied Physics* 33(19):2407, DOI: 10.1088/0022-3727/33/19/311, September 2000.
- [4] M. S. J.Zhu, "Measurements of 3D slip velocities and plasma column lengths of a gliding arc discharge," <http://dx.doi.org/10.1063/1.4906928>, Munchen, 2015.
- [5] J.C. Sagás, A. H. Neto, A.C. P. Filho, H.S. Maciel, "Electrical and optical characterization of a gliding arc discharge in air," <https://www.researchgate.net/publication/264889979>, Brazil, 2015.
- [6] A. c. A. Ranaivosolarimanana, "GlidArc-I And GlidArc II Reactors. Physical Properties And Electrical Diagnostics," *Buletinul Institutului Politehnic Din Iasi, Iasi*, 1999.
- [7] S. Kalra, "Transient Gliding Arc for Fuel Ignition and Combustion Control," *Drexel Plasma Institute, Drexel University, Philadelphia*, 2004.
- [8] J. Diatczyk, "Power Consumption of Gliding Arc Discharge Plasma Reactor," *International Journal of Plasma Environmental Science & Technology.*, Vols. Vol.5, No.1, p. 15, 2011.
- [9] B. Hnatiuc, "Experimental analysis of a double-spark ignition system," *Czechoslovak Journal of Physics*, Vols. Vol. 56 (2006), No. 8, p. 4, 2006.
- [10] L. F. C. Rehmet, "High speed video camera and electrical signal analyses of arcs behavior in a 3-Phase AC arc plasma torch," p. 6, 31 July 2015.
- [11] Y. K. Z. Sun, "Optical diagnostics of a gliding arc," *Optical Express*, Vols. Vol. 21, No. 5 , p. 3, 2013.
- [12] Y. K. Z. Sun, "Optical diagnostics of a gliding arc," *OPTICS EXPRESS*, Vols. Vol. 21, No. 5 , p. 1, 2013.
- [13] B. Hnatiuc, "Experimental analysis of a double-spark ignition system," *Czechoslovak Journal of Physics*, Vols. Vol. 56 (2006), No. 8, p. 5, 2006.
- [14] Y. K. Z. Sun, "Optical diagnostics of a gliding arc," *OPTICS EXPRESS*, Vols. Vol. 21, No. 5 , p. 3, 2013.