

An Approach for controlling Household Electrical devices using Bluetooth communication system via Smartphone devices

Miran Hikmat Mohammed Babban

Iraq Kurdistan Region – University of Sulaimani
miran.mohammed@univsul.edu.iq

Abstract. Technologies software applications and hardware devices in general play a big role in everything in our life, which make things to be done quickly and easily comparing to some few years ago. Even though, these rapid developments in technologies comprises electrical devices that we are use in daily manner as well. In this research, an idea is applied to provide a smart house technology which can control any electrical for any domestic device in households, this is done by using Bluetooth networking connection through using mobile smartphone. The main goal of this research is to show that there are possibilities to control any electrical devices in home via controlling them remotely and at any time and at anywhere around the home. So, it provides easy accessibility to switch on or off devices, also it delivers safety use of those electrical devices.

Keywords. smart house, Bluetooth, Arduino, Sensors, networking.

1. Introduction

Smart house is considered as one of the new development in our technologies world which has been developed along with other skills in different working areas. In addition, many researchers recently start with using this kind of smart techniques in domestic households in order to provide automatic connection to different electronic devices remotely [1].

In other word, the term smart house refers to provide a communication network around the house that has ability to connect different appliances and allow them to be controlled automatically and remotely either via local Wi-Fi or online connection using internet [2].

As Most of the researchers have used Wi-Fi and online internet connection in their researches, and there are not any ideas for using Bluetooth communication has been conducted, so that this research concentrates on using Bluetooth technology, which is create a peer to peer communication between the smartphone one side and the electrical devices on the other side.

Along with Bluetooth device, in this research another idea has been used which is an Arduino UNO (R3) has been used as well, which work as the main center for exchanging the data that receive and send among the devices. Moreover,

The output of this research will illustrate that there are possibilities to propose a smart house technique with using Bluetooth networking and Arduino components in a very simple way. Also, it will help household family to control their devices in their household with easy accessibility and in safety way.

This research paper is prepared with different sections, which shows the quality of the proposed work and discussing how it can help the community with using their domestic devices certainly and safely to prevent any electrical shock dangerous. Also, it shows how the main comparison between the proposed projects in this research and other systems in the same area for different uses. Figure 1 shows the general view of smart house with different electrical devices connections.



Figure 1. Smart house view.

2. Literature Review

Arduino is electronic platform, which is open source and based on software and hardware, and it has ability read and write data from the computer to board and vice versa. Also, it has many functional capabilities for example, activating a motor, turn on light bulb, connecting to internet and exchange data online and many other capabilities [3].

Moreover, Arduino has been used in many different projects as it can run on many platforms such as Window, Mac and Linux. And, there are many types of Arduino board which are:

- Arduino UNO (R3)
- LilyPad Arduino
- Red Board.
- Arduino Mega (R3)
- Arduino Leonardo

Each of them are different from each other in the way of processor, memory, Digital I/O and Analogue I/O. Figure 1 shows the different types of Arduino, and the table 1 show the list of different Arduino and their properties (Castro, 2017) [4].

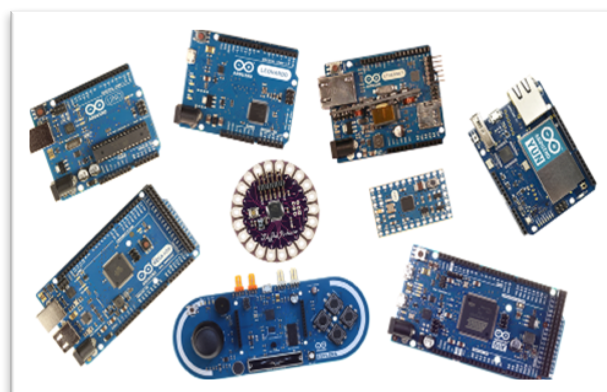

Figure 2. Arduino different types

Table 1. The different types of Arduino and their properties

Arduino Board	Processor	Memory	Digital I/O	Analogue I/O
Arduino Uno	16Mhz ATmega328	2KB SRAM, 32KB flash	14	6 inputs, 0 output
Arduino Due	84MHz AT91SAM3X8E	96KB SRAM, 512KB flash	54	12 inputs, 2 outputs
Arduino Mega	16MHz ATmega2560	8KB SRAM, 256KB flash	54	16 inputs, 0 output
Arduino Leonardo	16MHz ATmega32u4	2.5KB SRAM, 32KB flash	20	12 inputs, 0 output

While smart house is an advanced house automatic system that can control any functionalities of devices such as temperature, television, security alarm, and any other devices that are performed by the resident of the house. Also, it works with wireless communication and remote control through smartphones, tablets and any other devices that's has ability to send and receive data among electrical devices [5].

In fact, there are two main types of smart house technologies wired system and wireless system, each of them have their functionalities and qualities. Also, it sends the data to the devices in order to deactivate or activate.

In wire system, the devices should connect directly to the main power circuits and this will lead to consume power in addition to electric shock dangers. Also, there are some kinds of wire system that installed in houses, for instance wires that installed in walls as twisted pair or optical fiber.

While in wireless system, there two main actions which are sender and receiver for this reason there are some types of connections which are Infrared, Wi-Fi connection and Bluetooth. Also, with wireless connection it can control the data transferring from and to devices remotely. While some devices that are connected in network works as the central of the communications [6].



Figure 3. Using smart devices to demonstrate the smart house

Also, most of the recent and most easiest way of communication with smart house is using Bluetooth communication, which is a kind of wireless communication technology that has short range of communication, that can operate within the house range for transferring data as peer to peer network. Also, it allows devices such as mobiles, computers and other peripheral devices to connect to each other. Moreover, the main advantages of using is to replace cables around home for communications, and it reduces the cost of buying a lot of wires, and it keeps homes clean and tidy [7].

Although Bluetooth has less capability for data transmission, it has two main features which makes it more preferable than Wi-Fi network devices, which are consume less electricity power than Wi-Fi, and it is less suffering or causing network interferences that Wi-Fi wireless devices do (8).

Many mobiles old versions and smartphones these days, has ability to connect with Bluetooth networking, this is due to the built-in radio in those devices. So that, these radio transfer to the other device that connected with for exchanging the data [7], [8].

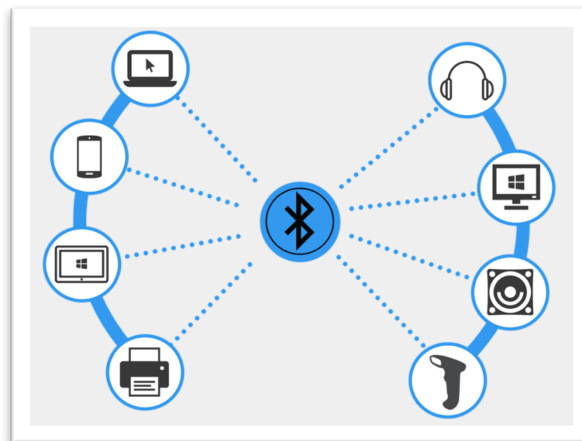

Figure 4. Bluetooth Networking

With Bluetooth communications, all devices other than computers and mobiles that could connect to Bluetooth communication could exchange the data successfully, and this is a good idea to automate all devices to operate remotely.

In term of security, Bluetooth provide high security comparing to other communications, because it connects to a single device at a time so there are not any multiple connections from other routes, and it sends data to other devices at the time they are paired together. These can ensure the securing of the content of data and in devices and at the time of transferring [8], [9].

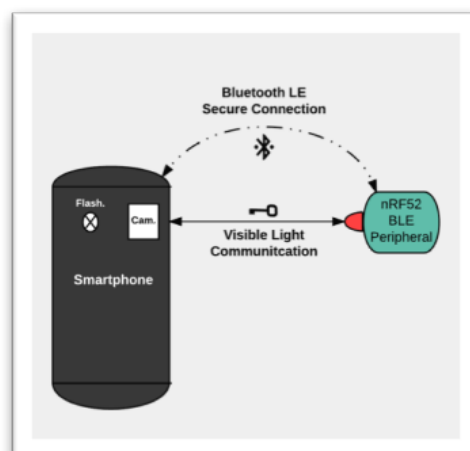

Figure 5. Secure Bluetooth communication.

3. Related work

The author of paper [10] tried to use Wi-Fi network system as local network in house in order to connect all the devices all together through local network. At the same time, the author used internet connection that can remotely can control all the appliances at home from anywhere outside the house. As it is clear from the diagram in figure 6, the author used server to gather all request for controlling the devices in house. This is including computer desktop, iPad, Smartphone and laptop as the controller devices.

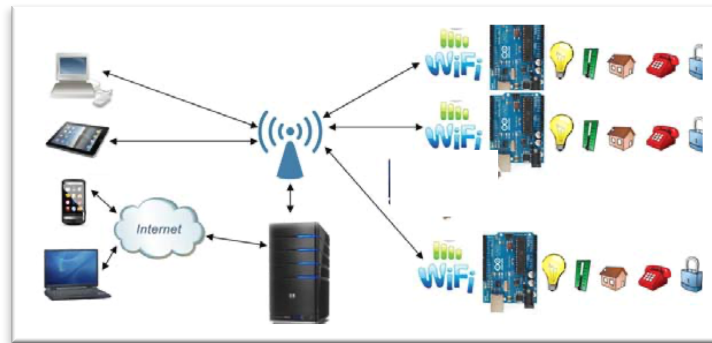

Figure 6. Network system for smart housing.

However, in paper [11], for smart house technology applications used internet web page to control devices in households. In this paper, the author used web interface that shows list of options to communicate with the list of devices remotely.

In addition, it provides a step of security to secure the system to be used by unauthorized people in order to keep all the devices safe. Also, it can be seen from the diagram in figure 7, that there is a database, which store information about the devices, which helps to control the right device at the right time.

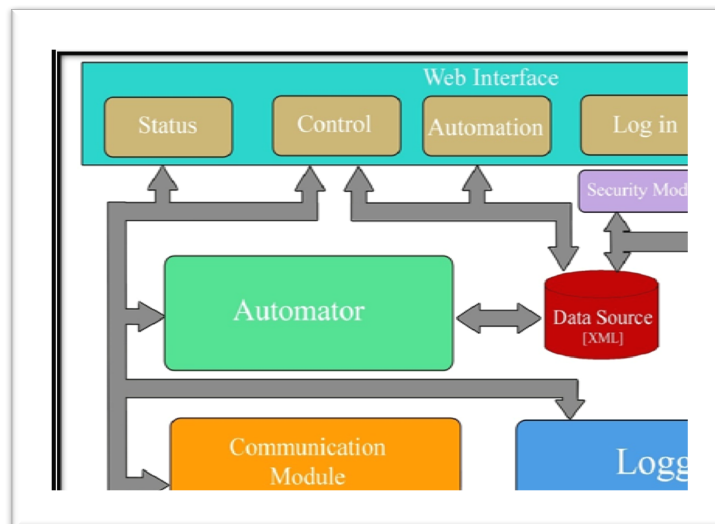

Figure 7. Internet web interface for smart house.

4. Implementation and Design

This paper, the idea of smart housing has been implemented on using Bluetooth communication network module and using Smartphone device which has an app called Bluetooth terminal can control the connected devices as peer to peer connection.

Also, for the electronic circuit, Arduino technology is used along with electronic components such as (wires, Bluetooth module device, Arduino Uno and electronic circuit board. All these devices have been tested for giving correct functionalities during the working process. Also, this paper has used Huawei nova 3 is used to control the devices remotely by using Bluetooth communication devices. In addition, the test has been conducted on using lamping a light with using a relay module connected with a lamp.

The first step starts with connecting the Bluetooth module with Arduino Uno circuit, this is to turn on the connection between the Bluetooth and Arduino Uno broadcasting the wave of the Bluetooth to be recognized by the allowed smartphones around the home. Fig 8 (a) (b) (c), illustrate the devices and the connections.

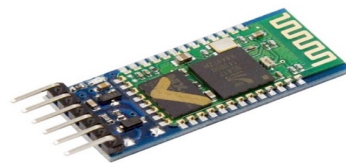

Figure 8 (a). Bluetooth device

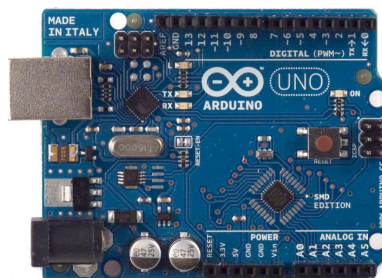

Figure 8 (b). Arduino Uno device

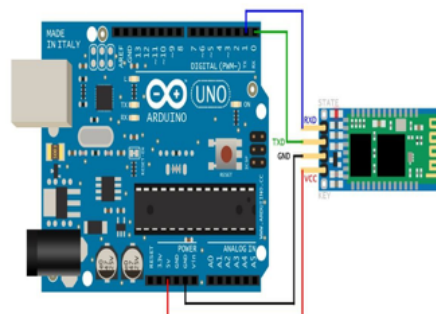

Figure 8 (c). Bluetooth device connected to the Arduino

Later, after the Bluetooth connected to the Arduino Uno, with wires, and it tested all the ports and they are attached to the correct pins carefully. The next step starts with connecting the Relay module with a Lamp, with careful connection to the indicated pins and wire (Positive and Negative).

The Positive wire port of the lamp will be cut and connected to the Relay Ports Normally Open (N.O) and Common Connection (COM). And the other side of the lamp connected to A.C power. Figure 9 (a) (b) (c) shows the devices and the complete connections of the modules.



Figure 9 (a). Relay Module device

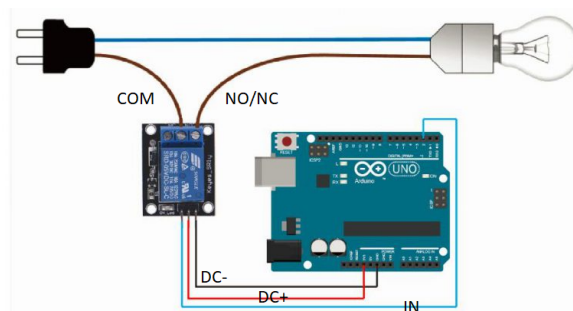

Figure 9 (b). The lamp connected to Relay Module device

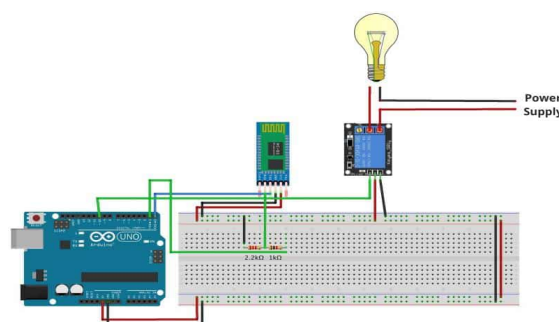

Figure 9 (c). The completed circuit connections

5. Result and Discussion

After the electronic circuit is completed and designed safely according to the electrical steps with giving attention to the electrical (Positive and Negative) ports. After that, the most important step is to connect the indicated smartphone with the circuit through the Bluetooth and this is can be done through Bluetooth terminal app on mobiles.

When the mobile is connected successfully to the circuit via Bluetooth, it can be seen the lighting of the Bluetooth will be changed, this means the synchronizing of the light will be differed from the state that does not connected.

Later, the mobile device can communicate with the electric circuit and control the functionalities of the circuit. This is after a specific programming code has been set for the circuit with Arduino programming language.

The programming instruction codes work on sending and receiving the instructions to turn on and off the lamp via mobile Bluetooth technology communication. When the appliances send the **1** via the terminal app the Relay detects the commands and light on the bulb, while the **0** turn off the light.

So that, the controller will be through using the smartphone that belong to the householders and this is kind of security that prevent others to communicate with the electronic circuit. Also, the Bluetooth connection will not need internet connections, that sometimes might lose the connectivity, beside the security issues might face from hackers and intruders.

Also, the connections via Wi-Fi routers, might also get problem, in case of resetting the router by anonymous, this will lead to lose the connectivity and establishing security issues. Also, routers have issue with connectivity and types of networking communications, because some are not allowed easy way of connection, thus will lead to untrusted communication between devices.

In addition, the cost of using Bluetooth is not as much as using Wi-Fi, Internet communications, because each has some amount of cost. For instance, Internet connections required domain and host to upload the required web pages to the website, and this is cost a lot and need monthly renewing payment. In any case of missing payment by card due to missing card or the card do not have got enough money, they system will stop and the domain will lose. So that, this will lead to lose the complete functionality of the circuit [12].

On the other hand, the Wi-Fi device has high cost especially for those usages for smart housing, which need a very high quality wireless wave and need continuous electric sources in order to operate the wireless device. Moreover, if the wireless connected to the internet at the same time, this will lead to security issues that might someone hack the system completely or partially that may lead to dangerous process in electric in circuit or the main electric house in general [13].

The figure 10 shows the final connection and electrical circuit for the Bluetooth communication, with light connected to the Relay, which is connected to the board in return, whenever the Bluetooth receive the command it will pass to the relay and the relay will operate the light based on the command from smartphone user of house securely.

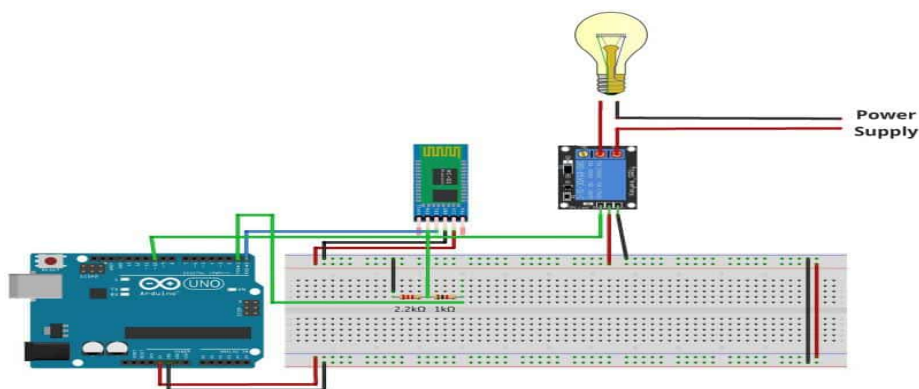

Figure 10. The complete Arduino system

6. Conclusion

To sum up, the general idea of creating a smart house is important which helps the householders to save energy and reduce the consumption of amount of electricity by them. Also, there are many ways to establish smart housing via different technology devices for different house appliances devices.

However, each of these technologies including Wi-Fi, Internet and Bluetooth have their advantages and disadvantages. Also, it has been resulted that using Bluetooth is much safer and lost cost required that the others. . However, the other technologies have some big role as well, for example controlling devices from distance but still there are technical problem with security.

7. Future Work

In future work for this paper it is possible to handle all the devices through Bluetooth with secure communication that can be applied to the householders via their smart devices at anywhere and at any time. And will be applied for multi devices such as Mobile smartphone, iPad and any other devices at once.

References

- [1]. R. Rehman, "Model of Smart System Based On Smart Grid, Smart Meter and Wireless Based Smart Appliances", IOSR Journal of Electrical and Electronics Engineering, vol. 1, no. 5, pp. 06-10, 2012.
- [2]. Kazarian and V. Teslyuk, "Optimization of Neural Network Structure for Smart House Systems", 2019 IEEE 2nd Ukraine Conference on Electrical and Computer Engineering (UKRCON), 2019.
- [3]. M. Silva, "ARDUINO GUIDE DEVICE FOR PEOPLE WITH VISUAL IMPAIRMENT", Nucleus, vol. 15, no. 2, pp. 159-162, 2018.
- [4]. W. Castro, "Residential design automation with Arduino use", Revista Acta Científica, vol. 8, 2017.
- [5]. Koen Kok et al., "Smart houses for a smart grid", IET Conference Publications, 2009.
- [6]. J. Dowling and M. Tentzeris, "'smart house' and 'smart-energy' applications of low-power RFID-based wireless sensors", 2009 Asia Pacific Microwave Conference, 2009.
- [7]. Garima, N. Agarwal and S. Reddy, "Design & development of daughter board for Raspberry Pi to support Bluetooth communication using UART", International Conference on Computing, Communication & Automation, 2015.
- [8]. K. Wang, P. Wang and Y. Wang, "The Research of Bluetooth Wireless Communication Network in NC System", 2009 International Conference on Networks Security, Wireless Communications and Trusted Computing, 2009.
- [9]. H. Jin and S. Zhao, "A New Parallel Instruction Model Based on Multi-Tasking Bluetooth Communication", 2016 12th International Conference on Computational Intelligence and Security (CIS), 2016.

- [10]. Elshafee and A. Hamed, "Design and Implementation of a WiFi Based Home Automation System", World Academy of Science, Engineering and Technology, vol. 68, 2012.
- [11]. R. Kodali, V. Jain, S. Bose and L. Boppana, "IoT based smart security and home automation system", 2016 International Conference on Computing, Communication and Automation (ICCCA), 2016.
- [12]. Tulenkov, A. Parkhomenko, A. Sokolyanskii, A. Stepanenko and Y. Zalyubovskiy, "The Features of Wireless Technologies Application for Smart House Systems", 2018 IEEE 4th International Symposium on Wireless Systems within the International Conferences on Intelligent Data Acquisition and Advanced Computing Systems (IDAACS-SWS), 2018.
- [13]. G. Tizazu, H. Hussen and Ki-Hyung Kim, "Secure session key exchange scheme for Smart Grid Home Area Networks", 2013 International Conference on ICT Convergence (ICTC), 2013.