

Study of double acting cylinder with two in and out piston rods

I.C. Duțu¹, T.Axinte², M.F. Duțu¹, C. Nutu³, L. Calancea², M. Diaconu²

¹ University Politehnica of Bucharest, Romania

² Research and Innovation Center for Navy, Constanța, Romania

³ Constanta Maritime University, Romania

Corresponding author: T. Axinte, tibi_axinte@yahoo.com

Abstract. This article represents research regarding use of pneumatic double acting cylinder with two in and out piston rods. A cylinder with two in and out piston rods in this paper is a pneumatic actuator. The cylinder with two in and out piston rods works only with compressed air. Besides, the compressed air usually has a pressure of between $2 \cdot 10^5$ Pa and $6 \cdot 10^5$ Pa. Cylinder with two in and out piston rods drive with solenoid can be used for various technical applications. In the paper all the circuits have cylinders with two in and out piston rods. These four circuits, simulate the operation of the cylinder with two in and out piston rods. We mention that the pneumatic and electro-pneumatic schemes given in this paper are made using FluidSim software from Festo.

Keywords. cylinder, rods, valve, actuator, lamp.

1. Introduction

A pneumatic double acting cylinder with two in and out piston rods is a device with double trestle. That creates motion only in a straight line, in contrast to circular motion of a pneumatic motor (air motor).

The pneumatic double acting cylinder with two in and out piston rods and double trestle is in many pneumatic tools, in industrial machinery or various other devices where linear motion is required.

Types of motion from pneumatic linear device include: pulling, pushing, blocking, clamping, lifting and descending. Besides, this twin cylinder has two in and out piston rods that move in parallel and that are coupled by a double trestle. The construction of devices guarantees minimum torsion when positioning and assemblies or moving tools.

The advantage is has having the same construction height, the double piston rod transmits at least twice the force compared to standard cylinders, [1].

The characteristics of the cylinder with two in and out piston rods are: compact units, easy and ready-to-install corrosion-resistant, low noise emission and dust emissions.

Adjustable parameters for a pneumatic device are classic, Table 1.

No.	Description	Value	Measurement unit
1	Piston diameter	$1 \cdot 10^{-3} \dots 1$	m
2	Piston position	0...4	m
3	Piston rod diameter	0...1	K
4	Mounting angle	0...360	deg
5	Reference velocity	0.1...2	m/s
6	Reference pressure	0.1...20	bar
7	Moving mass	0.01...1000	kg

Table 1. Adjustable parameters of device

The cylinders with two in and out piston rods and double trestle are used depending on the functions of the circuits. These devices are mounted on both pneumatic and electro-pneumatic circuits, Figure 1.



Figure 1. Cylinder with two in and out piston rods

In electro-pneumatic and pneumatic schemes, the device is represented by a specific symbol, Figure. 2.

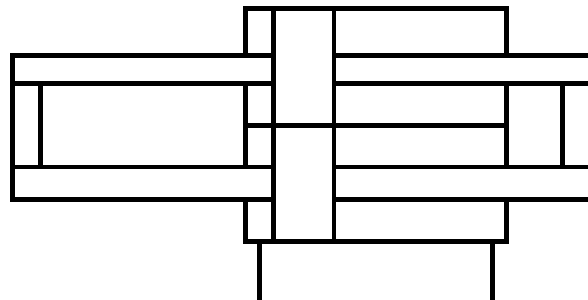

Figure 2. Symbol of cylinder with two in and out piston rods

1. The pneumatic circuits

The first pneumatic circuits with has a very simple construction.

A cylinder with two in and out piston rods delivered from this pneumatic installation is often used in areas of extreme temperatures due to the safety of using air rather electricity or hazardous chemicals. Moreover, the pneumatic installation who has a cylinder with two in and out piston rods is an optimal option, [2].

The following pneumatic scheme presented in this article operates only when to 5/2 way valve will be given a manual command, using SI.

In the table below there are given the component devices used in the first pneumatic scheme, [3].

Description	Number of components
Compressed air supply	1
Air Filter	1
5/2 way valve	1
Throttle valve	2
Cylinder with two in and out piston rods	1

Table 2. Actuators in the first pneumatic circuit

The first pneumatic scheme studied by authors has one linear drive 1-1, Figure 6.

Cylinder with two in and out piston rods 1-1

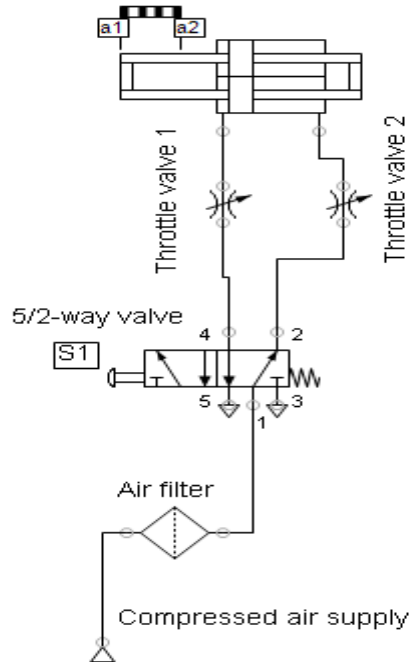

Figure 3. First pneumatic circuit using one cylinder

The first pneumatic circuit operates if the operator presses S1 button of the 5/2 way directional valve with spring. Then, the piston rods (1-1) moves from point a1 to point a2. After that, the piston rods returns from point a2 to point a1, because the 5/2 way directional valve has a spring, Figure 7.

Cylinder with two in and out piston rods 1-1

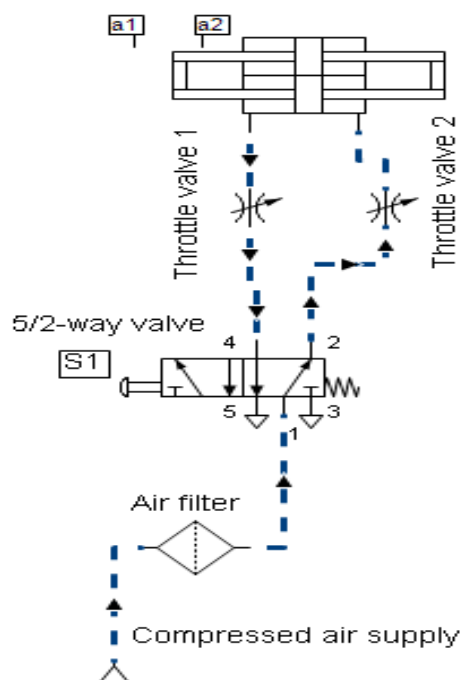

Figure 4. Simulation of the first pneumatic circuit. Simulation

The diagrams given show variation of the following functional parameters of the cylinder with two piston rods (Cyl 1-1), Figure 8:

- Position – x [mm];
- Velocity – v [m/s];
- Acceleration – a [m/s²].

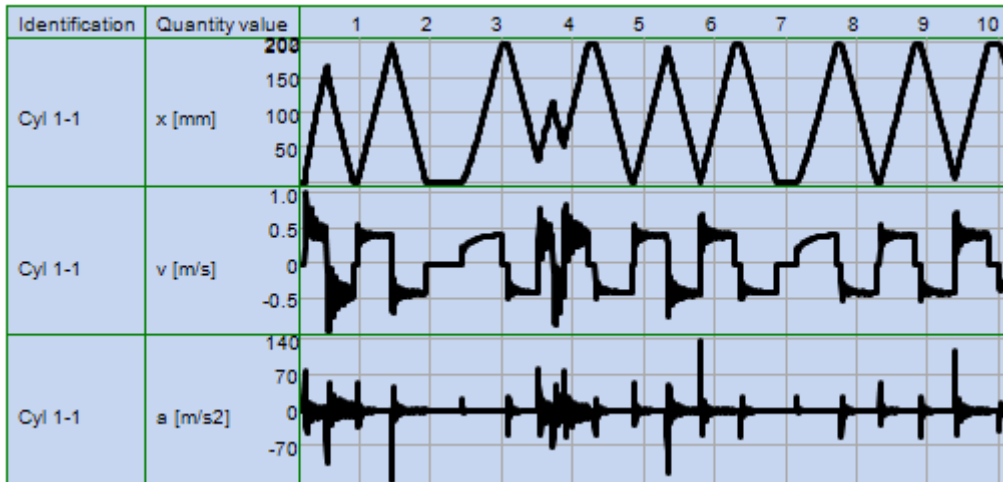

Figure 5. Diagrams of functional parameters variations of the Cyl 1-1

In the table below there are given the component devices used in the second pneumatic scheme.

Description	Number of components
Compressed air supply	1
Start-up valve with filter control valve	1
4/2 way solenoid valve	1
Throttle check valve	4
Cylinders with two piston rods	2

Table 3. Components of the second pneumatic circuit.

The second pneumatic circuits studied uses two cylinders with two piston rods, Figure 9.

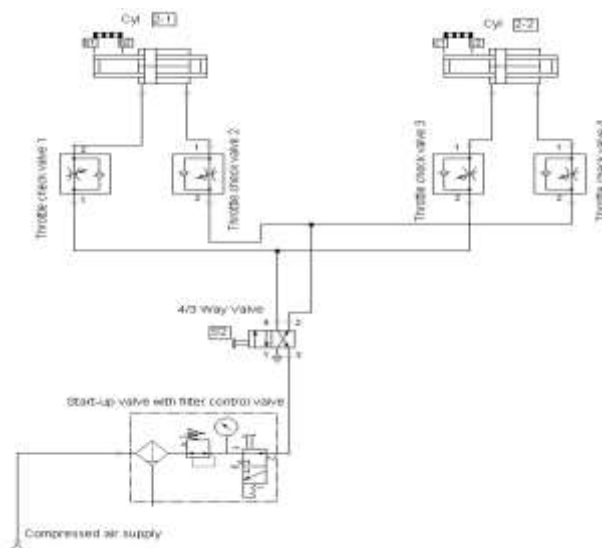

Figure 6. Second pneumatic circuit using two actuators

If the operator presses button S2 then the cylinders open together. In this case, the piston rods (2-1) moves from point b1 to point b2 and the piston rods (2-2) moves from point c1 to point c2. After that, both pistons return to their starting points, because the 4/2 way solenoid valve has a spring, Figure 10.

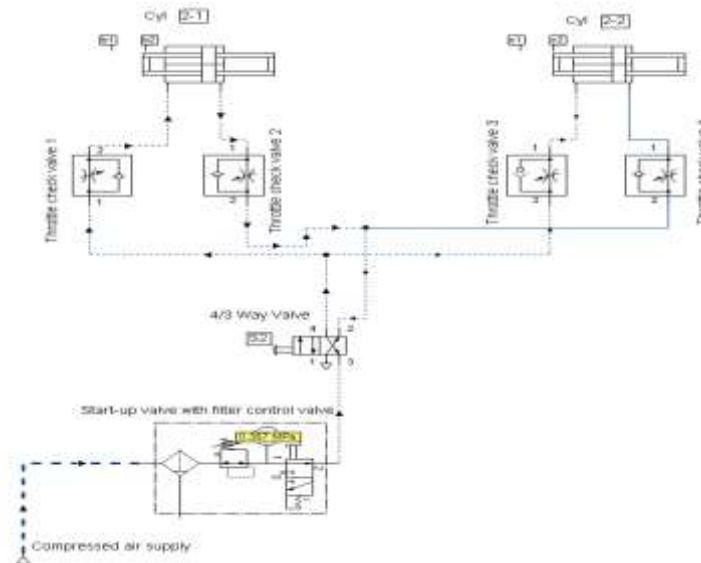

Figure 7. Simulation of the second pneumatic circuit

2. The electro-pneumatic circuits

Electro-pneumatic circuits is more widely used for large applications. In this installations, the signal medium is the electrical signal either DC or AC source is used. Therefore, operating voltage from around 12V to 220V are often used. The final control valve is activated cylinder with two in and out piston rods.

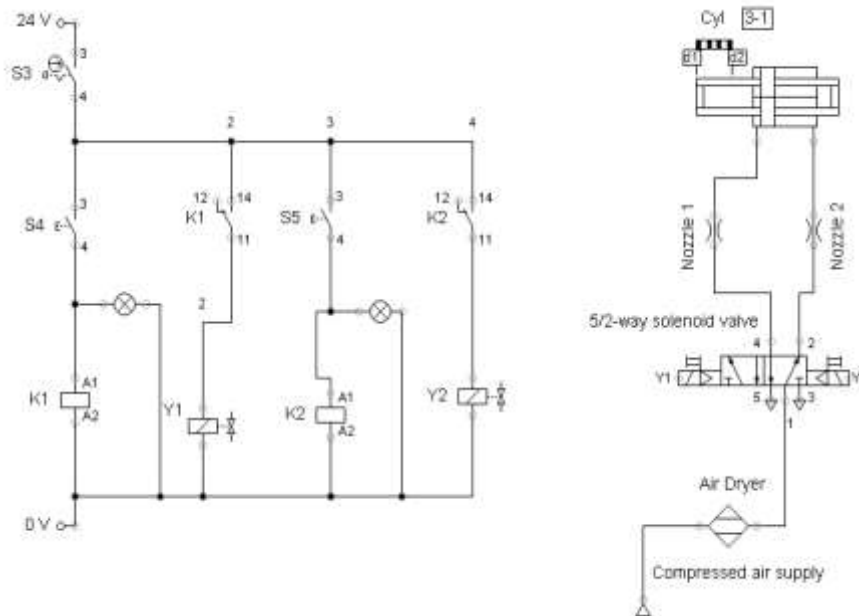

Figure 8. First electro-pneumatic scheme

The first electro-pneumatic circuit comprises a few basic electrical and pneumatic components. It must be noted that the authors used a latched 4/3 – way solenoid valve, having a “memory”. This “memory” has an effect on commands given by the operator of this installation, Figure 11.

In the table below there are given the component devices used in the first pneumatic scheme, [4].

Description	Number of components
Compressed air supply	1
Air dryer	1
5/2 way solenoid valve	1
Nozzle	2
Cylinder with two piston rods	1
Relay	2
Valve solenoid	2
Lamp	2

Table 4. Devices in the first electro-pneumatic scheme.

In order to operate the electro-pneumatic circuit shown in figure 12, having one cylinder with two piston rods (3-1). In this case, the first time the operator has to press S3 button. Afterwards, he has to press S4 button. The piston rods moves from point d1 to point d2 and lamp 1 shows a yellow signal, Figure 12.

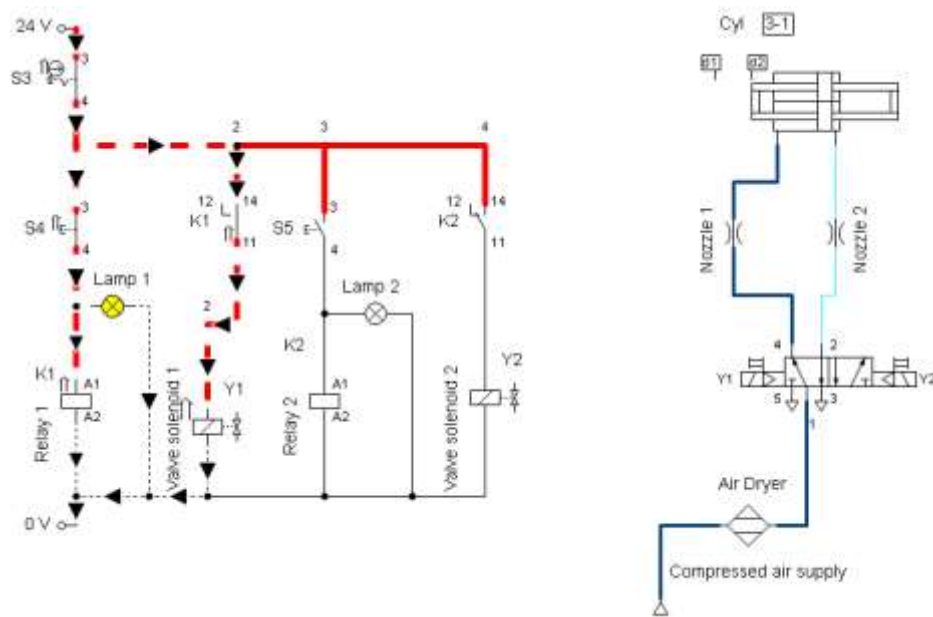

Figure 9. Opening the first electro-pneumatic scheme. Simulation

In order to close the first electro-pneumatic circuit, the operator must press button S5. The piston rods moves now from point d2 to point d1 and lamp 2 shows a green signal, Figure 13.

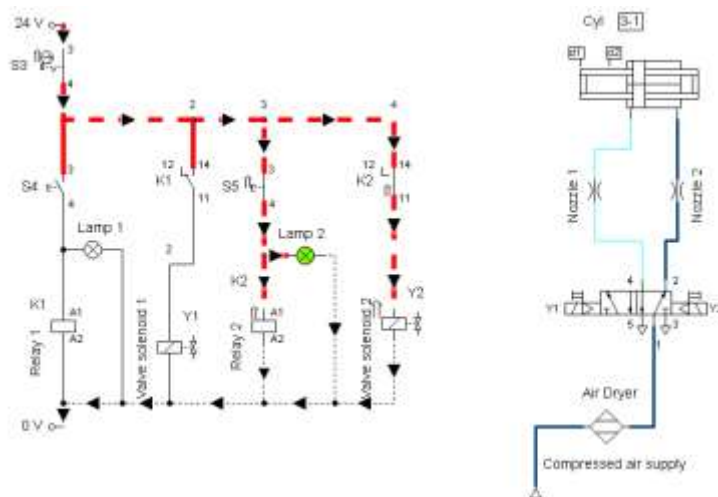

Figure 10. Closing the first electro-pneumatic scheme. Simulation

A development of an electro-pneumatic installation consists in further improvement with logic module and capacity proximity, [5].
 Otherwise, the second electro-pneumatic, using a cylinder with two piston rods (4-1), Figure 14.

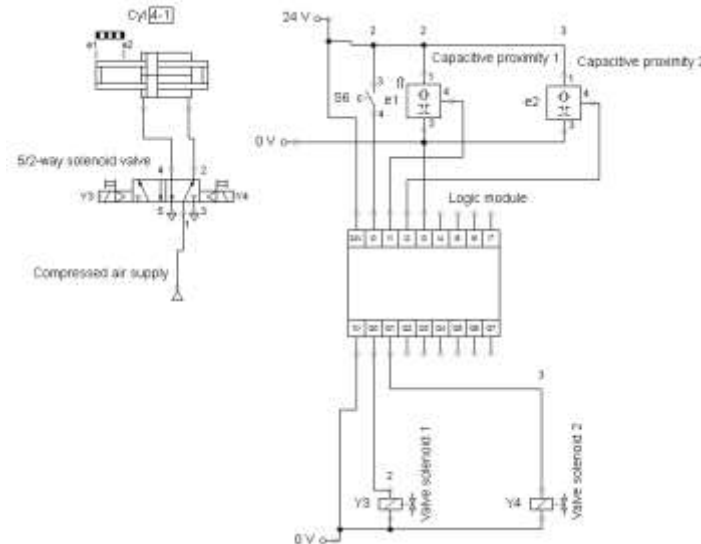

Figure 11. Second electro-pneumatic circuit using a logic module

In Table 5 below are given some important actuators used in the second electro-pneumatic scheme.

Description	Number of components
Compressed air supply	1
5/2 way solenoid valve	1
Cylinder with two piston rods	1
Capacity proximity	2
Valve solenoid	2
Logic module	1

Table 5. Devices in the first electro-pneumatic scheme.

The next figure show the movement of the cylinder with two piston rods (4-1). The operator must press the S6 button to open the second electro-pneumatic circuit, in order to open scheme, [6].

Thus, the cylinder with two piston rods moves from point e1 to point e2, Figure 15.

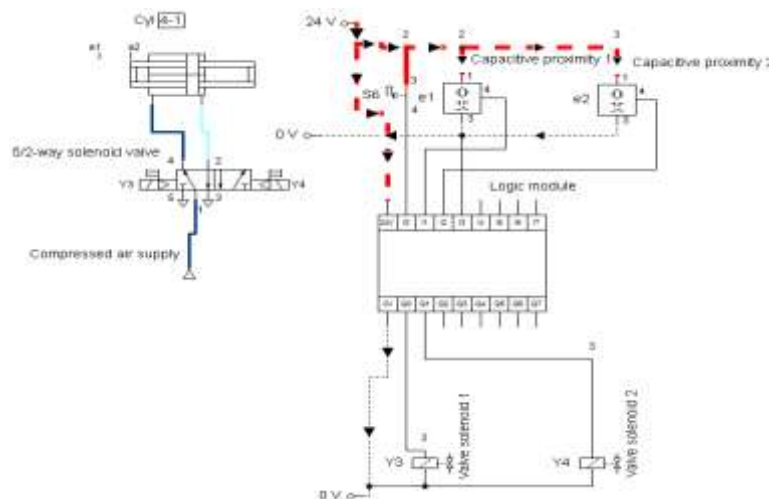

Figure 12. Second electro-pneumatic circuit using logic module. Simulation

3. Conclusions

The electro-pneumatic circuits which has a cylinder with two piston rods offer some important advantages over traditional electro-pneumatic circuits using that use multiple cylinders.

Moreover, the cylinder with two piston rods is easy to assemble and disassemble in pneumatic and electro-pneumatic circuits.

The circuits presented in the manuscript can be used in practice.

We want that the research of the circuits that have cylinder with two piston rods to develop in the future.

4. Acknowledgement

This work was supported by a grant of the Romanian Ministry of Education and Research, CCCDI – UEFCDI, project number PN-III-P2-2.1-PTE_2019-0446, within PNCD III, funding contract no.53PTE/23.09.2020, project title “Hydrophilic auto-chassis for high energy efficiency operation of interchangeable equipment intended for performing public utility work”, acronym ASHEUP, research direction 3. Econano-technologies and advanced, subdomain Advanced materials.

References

- [1] DUMITRESCU, C., POPESCU, T.C., DUMITRESCU, L., VASILIU, D., Modeling simulation and test of the high pressure relief valves, Proc of 14-th Annual Industrial Simulation Conference ISC’2016. pp. 85-89, 2016.
- [2] PANAITESCU, M., DUMITRESCU, G. B., SCUPI, A., Sustainable Pneumatic Transport Systems of Cereals, The International Conference on Environment, Energy, Ecosystems and Development, Vol. 1, pp. 129-134, 2013.
- [3] DUMITRACHE, C.L., DELEANU, D., Sloshing effect, Fluid Structure Interaction analysis, IOP Conferences Series: materials science and Engineering 916(1), 2019.
- [4] BIRIS, S., PARASCHIV, G., MAICAN, E., UNGUREANU, N., MANEA, M., VLADUT, V., Present and future in the field of alternative energy use, Scientific Papers-INMATEH, vol. 1, pp. 13-22, 2009
- [5] www.festo-didactic.com.
- [6] NĂSTĂSESCU, V., GAVRILĂ, L., CONTROLLED FLOW SIMULATION USING SPH METHOD, Scientific Research & Education in the Air Force-AFASES, Vol. 1, 2012.