

SIMULATION OF AN ELECTRO-HYDRAULIC CIRCUIT FOR ALARS

I.C. Duțu¹, T. Axinte², O. Vlăduț¹, R. Damian², M.Fl. Duțu¹

¹ Politehnica University of Bucharest, Romania

² Research and Innovation Center for Navy, Constanța, Romania

Corresponding author: T. Axinte, tibi_axinte@yahoo.com

Abstract. In this paper, the authors present hydraulic and electro-hydraulic simulations of the circuits needed for ALARS (Automated Launch and Recovery System). In fact, the ALARS is used to launch the side-scan sonar into the sea. First hydraulic circuit has the following devices: tank, filter, fixed displacement pump, check valve, 4/3- way valve with two buttons, throttle valve, pressure relief valve and hand lever valve, tanks reservoir, filter and double acting cylinder (Cy 1-1). Afterwards, second hydraulic circuit has the following devices: pump unit, 4/2-way hand lever valve, throttle valve and two double acting cylinders (Cy 2-1 and Cy 2-2). Forward, the first electro-hydraulic circuit has the following devices: lamp, valve solenoid, pressure relief valve, double acting cylinder (Cy 3-1), throttle valve, 4/2-way solenoid valve, fixed displacement pump, valve displacement pump and tanks. Ultimately, the second electro-hydraulic circuit has the following devices: tank, pump unit, pressure relief valve, double acting cylinders (Cy 4-1 and Cy 4-2), relay, valve solenoid, and lamp.

Keywords. ALARS, side-scan, sonar, circuit, valve.

1. Introduction

The side-scan sonar is a type of sonar that is used to efficiently create an image of large areas of the sea floor. Besides, this device is used for mapping the sea floor for a variety of purposes: identification and detection of underwater objects or bathymetric characteristics, Figure 1.

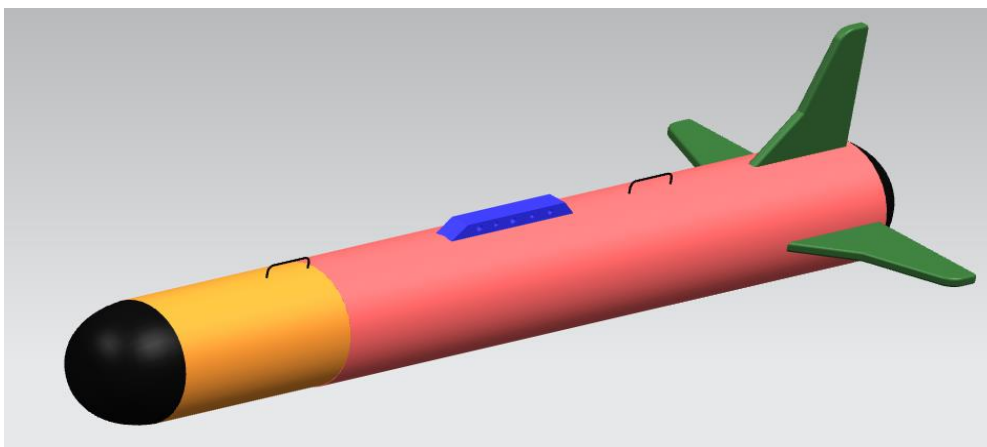

Figure 1. Side-scan sonar

The ALARS (Automated Launch and Recovery System) has the role of launching/recovering a side-scan from the sea, Figure 2.

To launch a side-scan sonar in the sea, the ALARS uses a hydraulic installation. Likewise, to recover side-scan sonar from the sea, the ALARS, must use the hydraulic system, [1].



Figure 2. Automated Launch and Recovery System

Depending on the weight, ALRS can use a single hydraulic cylinder or two hydraulic cylinders, [2].

2. The ALARS with hydraulic circuits

All hydraulic circuits are connected to the ship's compressor, [3].

The first hydraulic circuit designed for ALARS, use only one cylinder (Cy 1-1), Figure 3.

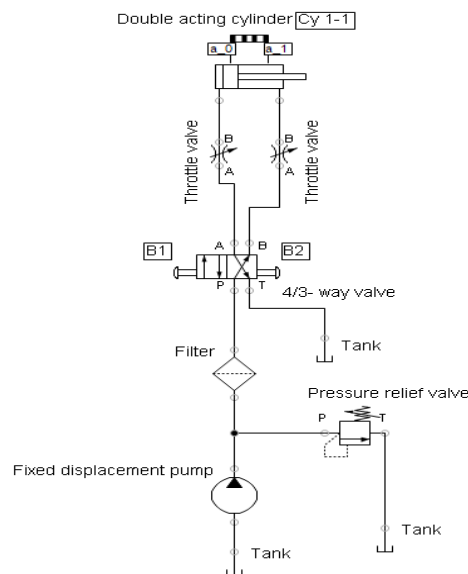

Figure 3. First hydraulic circuit of ALARS

In the table below there are given eleven components of devices used in the first hydraulic scheme, [4].

Table 1: The devices of the first hydraulic scheme

Description	Number of components
Tank	3
Filter	1
Fixed displacement pump	1
Check valve	1
4/3 -way valve with two buttons	1
Throttle valve	2
Pressure relief valve	1
Double acting cylinder (Cy 1-1)	1

In the first hydraulic circuit, the B1 and B2 buttons belongs to the 4/3-way valve. When the operator presses the B1 button, the piston rod moves from point a₀ to point a₁, Figure 4. The piston rod is part of double acting cylinder (Cy 1-1), [5].

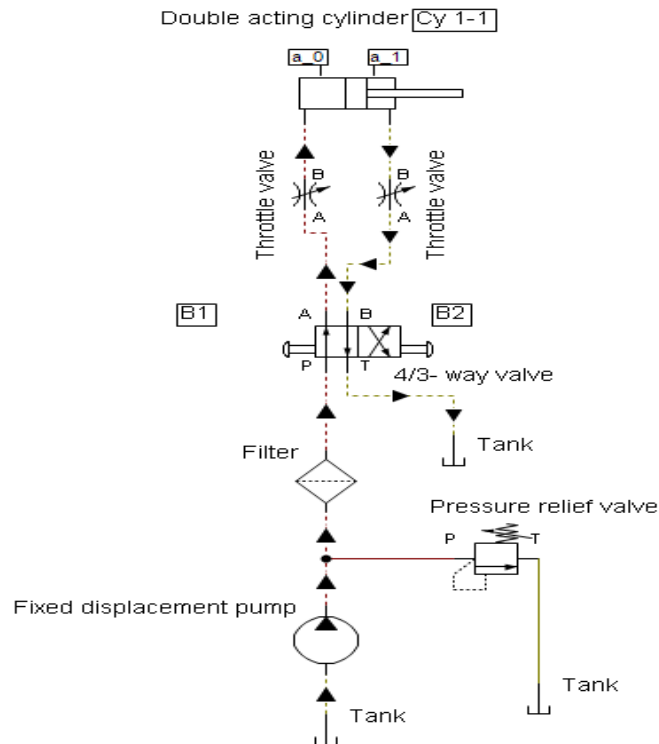

Figure 4. First hydraulic circuit of ALARS. Simulation I.

After that, the operator presses the B2 button, the piston rod return from point a₁ to point a₀, because the 4/3-way valve is equipped with two springs, Figure 5.

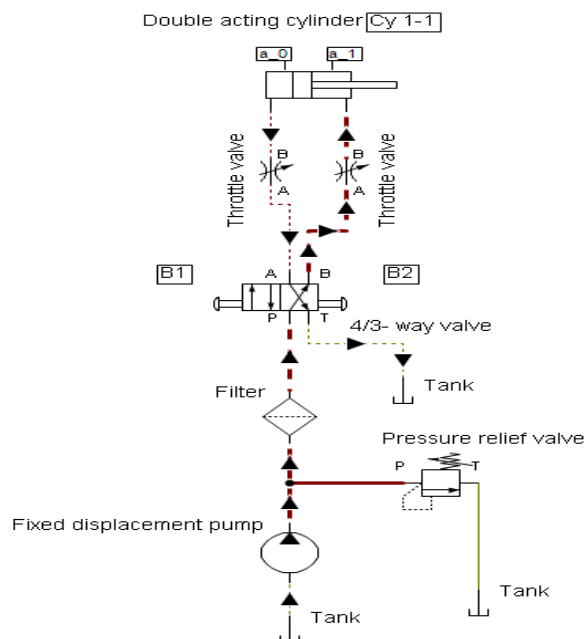

Figure 5. First hydraulic circuit of ALARS. Simulation II.

The diagrams given show variation of the following functional parameters of the pneumatic (Cy 1-1), from ALARS: position(x) and velocity(y), Figure 6.

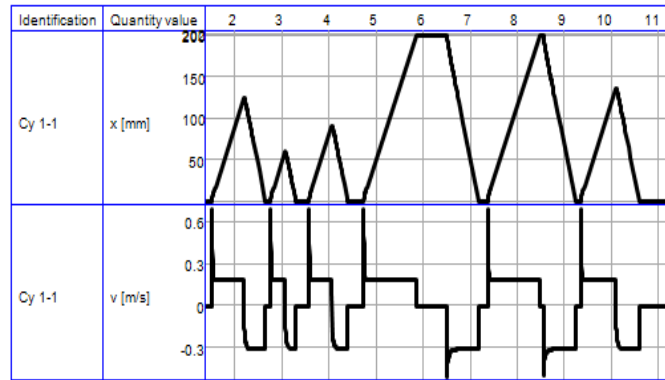

Figure 6. Diagram of first hydraulic scheme

The second hydraulic circuit studied uses two cylinders from ALARS, Figure 7.

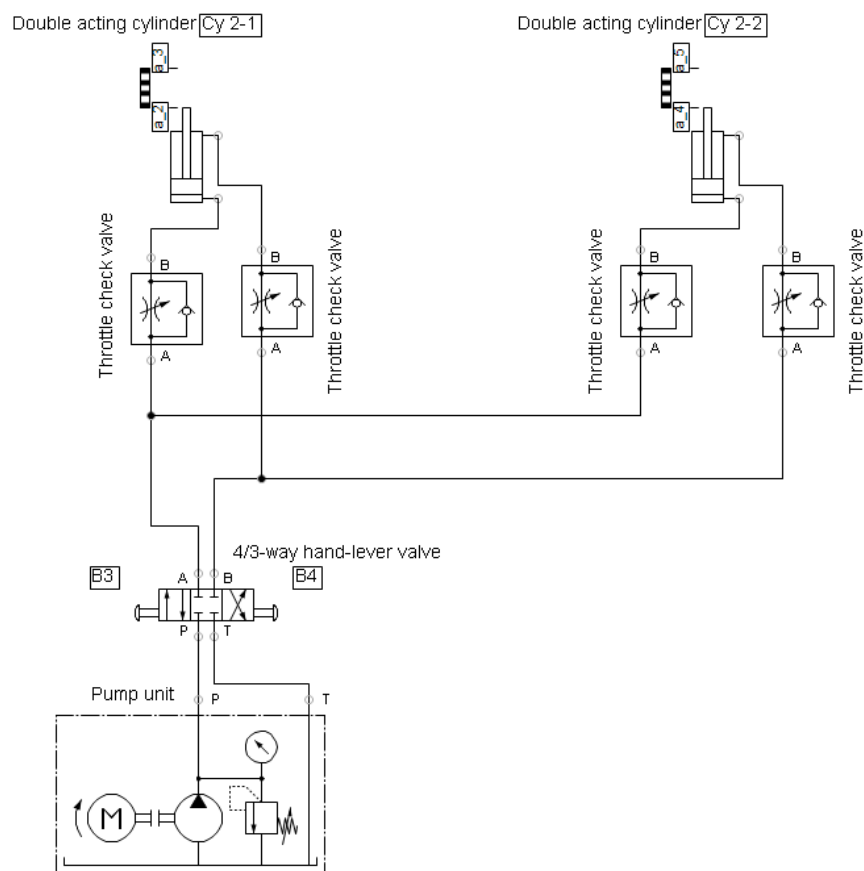

Figure 7. Second hydraulic circuit of ALARS

In the table below there are given eight components of devices used in the second hydraulic scheme.

Table 2: The devices of the second hydraulic scheme

Description	Number of components
Pump unit	1
4/2-way hand lever valve	1
Throttle valve	4
Double acting cylinder (Cy 2-1 and Cy 2-2)	2

The second hydraulic circuit designed for ALARS, uses two cylinders (Cy 2-1 and Cy 2-2), Figure 7.

If the technician presses B3 button which belong to 4/2-way hand valve, then the cylinders open together, [6].

In this case, the piston rods (Cy 2-1) moves from point a₂ to point a₃ and the piston rods (Cy 2-2) moves from point a₄ to point a₅, Figure 8.

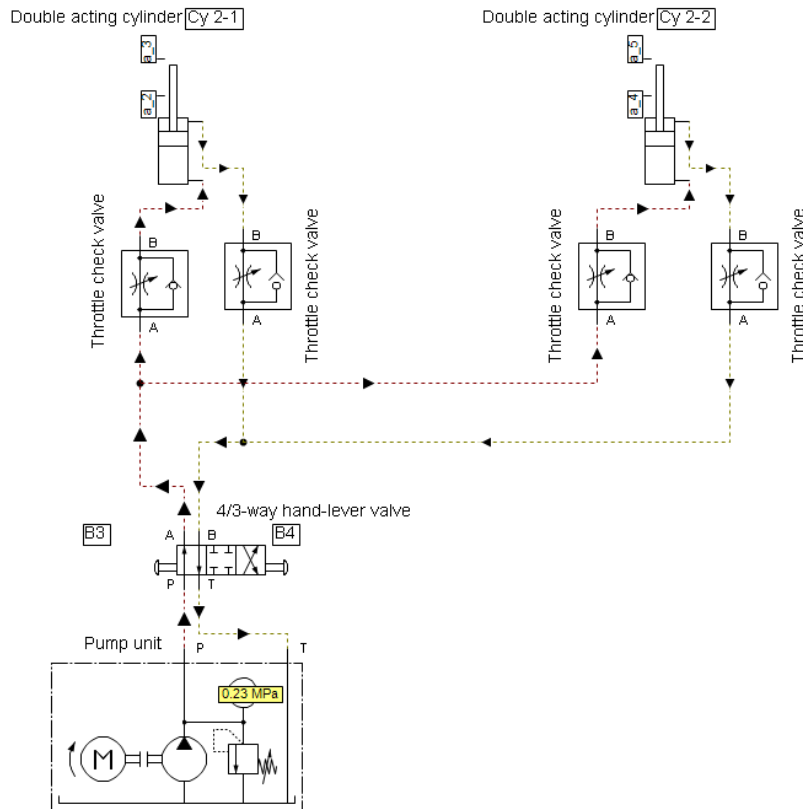

Figure 8. Second hydraulic circuit of ALARS. Simulation I.

If the technician presses B4 button which belong to 4/2-way hand valve, then both pistons return to their starting points, Figure 9.

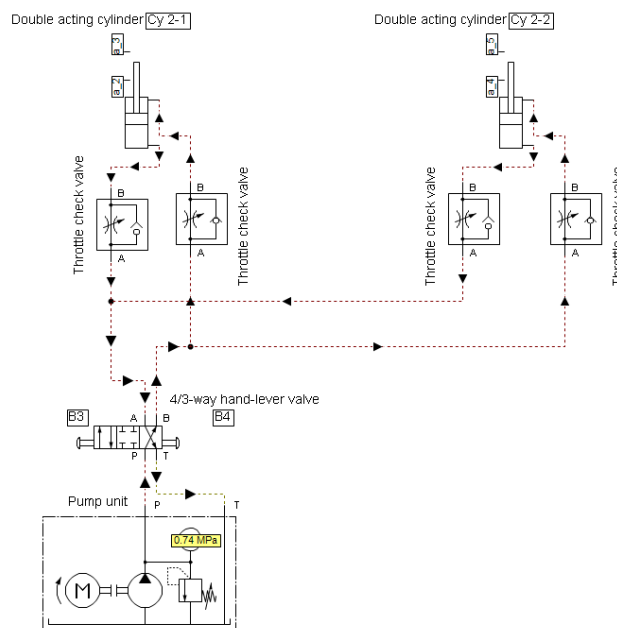

Figure 9. Second hydraulic circuit of ALARS. Simulation II.

In the table below there are given eight components of devices used in the second hydraulic scheme, [7].

Table 2: The devices of the second hydraulic scheme

Description	Number of components
Pump unit	1
4/2-way hand lever valve	1
Throttle valve	4
Double acting cylinder (Cy 2-1 and Cy 2-2)	2

The second hydraulic circuit designed for ALARS, uses two cylinders (Cy 2-1 and Cy 2-2), Figure 9. If the technician presses B3 button which belong to 4/2-way hand valve, then the cylinders open together, [8].

In this case, the piston rods (Cy 2-1) moves from point a₂ to point a₃ and the piston rods (Cy 2-2) moves from point a₄ to point a₅, Figure 10.

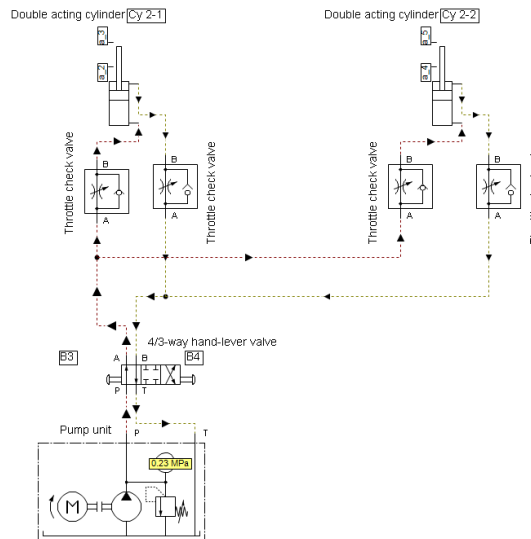

Figure 10. Second hydraulic circuit of ALARS. Simulation I.

If the technician presses B4 button which belong to 4/2-way hand valve, then both pistons return to their starting points, Figure 11.

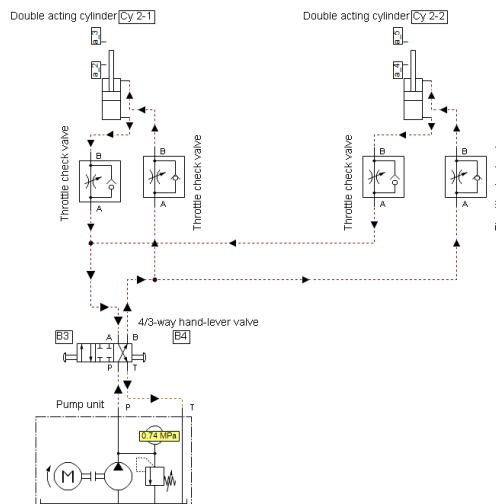

Figure 11. Second hydraulic circuit of ALARS. Simulation II.

3. The ALARS with electro-hydraulic circuit

Modern ALARS with side-scan sonar uses electro-hydraulic circuit, [9].

The first electro-hydraulic circuit designed for ALARS, use only one cylinder (Cy 3-1), Figure 12.

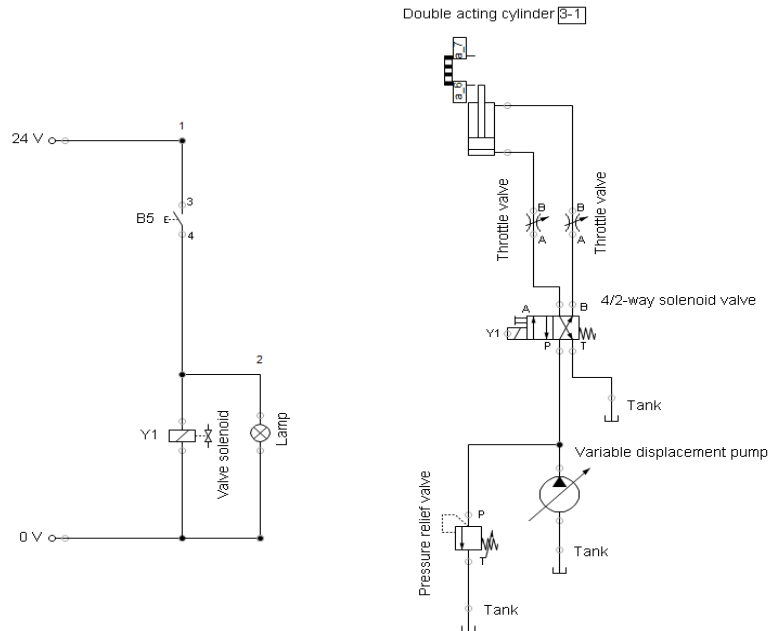

Figure 12. First electro-hydraulic circuit of ALRS

In the table below there are given twelve components of devices used in the first hydraulic scheme.

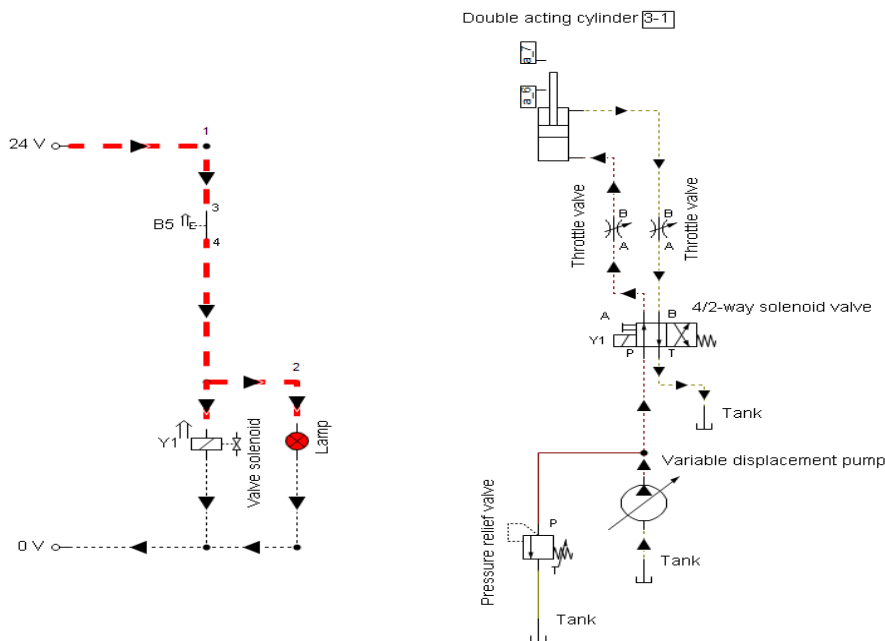

Figure 12. First electro-hydraulic circuit of ALARS. Simulation.

In order to operate the electro-hydraulic circuit shown in figure 12, having one hydraulic (Cy 3-1). In this case, the first time the technician has to press B5 button. The piston rods moves from point a₆ to point a₇ and lamp shows a red signal (labor protection). Afterwards the piston rod return to point a₆, because 4/2-way solenoid valve has spring, Figure 12.

Table 3: The devices of the first electro-hydraulic scheme

Description	Number of components
Tank	3
Valve displacement pump	1
Fixed displacement pump	1
4/2 -way solenoid valve	1
Throttle valve	2
Double acting cylinder (Cy 3-1)	1
Pressure relief valve	1
Valve solenoid	1
Lamp	1

In order to operate the electro-hydraulic circuit shown in figure 13, having two hydraulic cylinders (Cy 4-1 and Cy 4-2). In this case, the technician has to press B6 button.

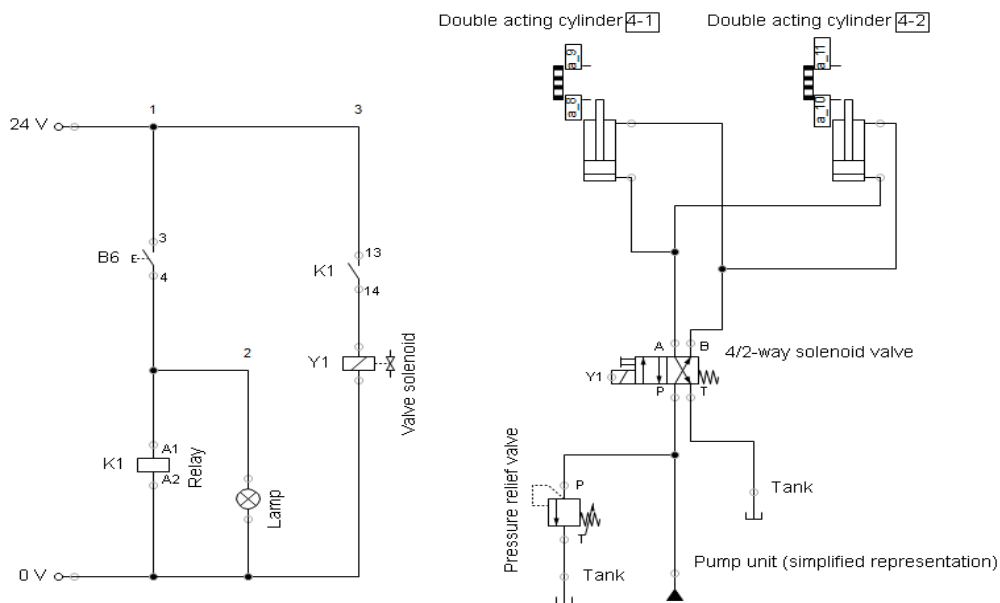

Figure 13. Second electro-hydraulic circuit of ALARS.

In the table below there are given eleven components of devices used in the second-hydraulic scheme.

Table 4: The devices of the second electro-hydraulic scheme

Description	Number of components
Tank	2
Pump unit	1
Pressure relief valve	1
4/2 -way solenoid valve	1
Double acting cylinder (Cy 4-1 and Cy 4-2)	
Relay	1
Valve solenoid	1
Lamp	1

The piston rods moves from point a_8 to point a_9 respectively point a_10 to point a_11. The lamp shows a red signal, for crew protection.

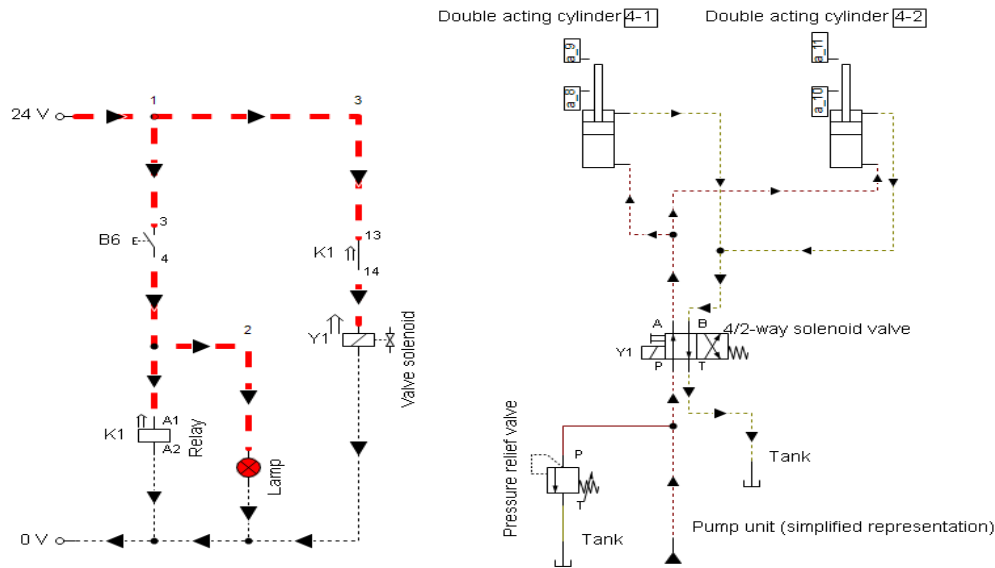

Figure 14. Second electro-hydraulic circuit of ALARS. Simulation.

Afterwards the piston rods returns to point a_8 and respectively point a_9, because 4/2-way solenoid valve has spring, Figure 14.

4. Acknowledgement

This research was supported by Executive Unit for Financing Higher Education, Research, Development and Innovation, UEFSCDI, under the PNCDI III – Programme 2, sub-programme 2.1., as follows partially from:

- submission code PN-III-P2-2.1-PTE-2019-0446, funding contract no. 53PTE/23.09.2020, project title “Hydrophilic auto-chassis for high energy efficiency operation of interchangeable equipment intended for performing public utility work”, acronym ASHEUP, research direction 3.Econanotechnologies and advanced materials, subdomain Advanced materials;
- submission code PN-III-P2-2.1-PED-2019-4123, funding contract no. 380PED/23.10.2020, project title “Multifunctional hexa-rotors tricopter for precision farming”, acronym 4.0-MHRT, project domain 1.Bioeconomics, subdomain 1.1.

5. Conclusion

The advantage of ALARS is that it can be mounted on any reserach vessel.

Moreover, the hydraulic system for an ALRS is designed so that:

- Ensures the operation of the winch;
- Ensures the operations of a telescoping A-frame c/w umbilical sheave.

In fact, the hydraulic and electro-hydraulic installations at ALRS, must operate at extreme temperatures.

If it fails electro-hydraulic circuits can then lose side-scan sonar.

In the future, we want to develop some more circuits for ALARS.

6. References

- [1] Pinto VH, Cruz NA, Almeida RM (2018) ALARS – Automated Launch And Recovery System for AUVs, Conferences OCEANS.
- [2] Panaitescu FV, Panaitescu M, Anton IA (2016) Experimental reseraches of marine wave parameters in the Black Sea basin. The 8th Edition of the International Conference „Advanced Topics in Optoelectronics, Microelectronics and Nanotechnologies”, ATOM-N, vol. 8, 2016.
- [3] Dumitrache CL, DELEANU D (2020) Controlling the parametric roll of a container ship model by changing the forward velocity, IOP Conference Series: Materials Science and Engineering.

- [4] www.krakenrobotics.com.
- [5] Marasescu D, Scurtu CI, Ristea M, Popa A, Vasile F (2015) Study of environmental influences on the functional parameters of the cooling systems, *Scientific Bulletin "Mircea cel Batran" Naval Academy*, vol. 18, issue 2, 2015.
- [6] Raicu G, Stanca C (2009) Advanced concepts in nanomanipulations, *Atom-N*, vol. 7297, pp. 355-359.
- [7] Hnatiuc B, Pellerin S, (2004) Electrical modeling and diagnostic of a luminescent discharge at high pressure. *The 9th International Conference on Optimization of Electrical and Electronic*, Brasov.
- [8] Biris S, Paraschiv G, Maican E, Ungureanu N, Manea M, Vladut V (2009) Present and future in the field of alternative energy use. *Scientific Papers-INMATEH*.
- [9] Dragan C (2015) Liquidity Risks, *Constanta Maritime University Annals*, vol. 23.