

# High Accurate Automatic School Bell Controller Based On ESP-32 Wi-Fi

**Riyadh Zaghlool Mahmood**

Department of Cyber Security, College of Computer Science and Mathematics, University of Mosul, Mosul, Iraq

E-mail: [riyadh.zaghlool@uomosul.edu.iq](mailto:riyadh.zaghlool@uomosul.edu.iq), ORCID: 0000-0001-7899-6475

**ABSTRACT.** Nowadays, the start and end bells for lessons in most schools are manually operated. Where the timings of operating the bell are inaccurate and depend on the accuracy of the watch of the authorized person or the school for this task, and sometimes the person may forget the time or delay or advance the time of ringing the bell. In this paper, a high accurate school bell controller based on ESP32 and DS3231 Real Time Clock module implemented with using Wi-Fi to correct the system time whenever switched OFF and ON despite of that the accuracy of the DS3231 RTC is  $\pm 40$  seconds per year with the absence of the Internet. The Bluetooth part of ESP32 is used to configure the system by inserting timetable of the school, the time delay for ringing bell, offset time for the country, and configuring SSID and PASS of the router

**Keywords:** Arduino, ESP\_32, DS3231, SSR, LCD, Bell.

## 1. Introduction:

Today, time is a valuable resource that everyone values. Time is a relentless force. Everything must be completed accurately and on schedule. Today's school and college bells are manually rung. There is therefore a serious issue with accuracy. Money and manpower are also necessary. In order to save money and manpower while also providing the maximum level of accuracy, we have here offered a system. A bell is a percussion instrument universities and schools are using it to alert students to the start of the day's classes and the need to switch between them. No other utility can perform this task. Therefore, it is a crucial tool for both elementary and secondary schools, as well as for industries and other businesses where the bell timer is essential for the day's operations. Long-distance audibility of clock towers was crucial at a time when clocks were too expensive for broad usage. Additionally, the number of universities, schools, and institutions is growing quickly as a result of literacy awareness. School period bells are currently operated manually. Each class's bell is rung by one of the staff members. Automatic college bell aids in preventing this [1]. In schools, this design eliminates the need to manually ring the bell because it will ring automatically at the appointed time.

Many digital clocks with bells that only chime at certain times are readily accessible in the market. For instance, an alarm clock and some bells that ring periodically and don't stop after a certain

time. Consider the Musical Clock. But our project has eliminated all of these restrictions. Only in accordance with our college's schedule does it ring. [2].

Today's advancements in science and technology are making daily life more convenient. Where science and technology are widely used in conjunction with machines or electronics, everything can be done more quickly and easily without wasting energy. Electronic gadgets are used in a variety of home and office appliances and work instruments to make human labor considerably lighter and simpler. So far, and in general, the school bell which indicates when it is time to start learning, break time and time to go home from school is rung manually, which is less effective and efficient for the picket teacher in charge of ringing the school bell. When learning starts, break time and time to go home from school [3].

The process of education is not separated from the role of the school that serves as a means of teaching learning activities. There are several components in the school as a part of the education process in teaching and learning. One of the important components to be aware of is the time discipline of learning teaching teachers and students. The discipline of teaching time is always marked by the schedule of change in learning time. Time in teaching change is known by the Sound of school bells. Teachers and students prepare to continue the process of learning to teach the next subject or school break time, it is done based on the prescribed scheduling, and time changing information in the school identical Marked with the sound of the bell rang, so the school bell becomes an effective medium in providing schedule turnover information in schools [4].

## **2. Literature Review**

In 2017, A microcontroller-based autonomous college bell with a monitoring system was presented by Shweta Butoliya et al. Through the universal asynchronous trans-receiver pin of IC P89V51RD2, which is used for serial communication, the GSM modem may connect with the microcontroller. Here, the baud rate is 9600. The initial stage involves setting the settings for SCON, TMOD, and TH1. To read the message, the microcontroller sends a series of AT instructions. A 336 LED display board (7 x 48 LED display) having 7 available rows and 48 available columns. Since each character has an 8-bit size, we shift every character column wise using 6 shift register ICs coupled in cascading [5].

In 2017, A design for an automated school bell based on a microcontroller was put out by Henry Ohiani Ohize and others. In this system, timings are set using a keypad and an 89c51 microcontroller. Once the timings are established, the controller activates the bell using a relay once the predetermined time has elapsed. This method employs cable communication between the controller and speaker rather than wireless connections for the speakers [6].

In 2018, The purpose of the project, which was published in a paper by Shabnum Rasool Shaikh, Snehal Suryakant Kale, et al., is to develop an Arduino-based real-time clock that plays the national song and rings a bell. This project is a digital circuit that switches the bell and anthem according to the schedule without human intervention [7].

In 2019, D. K. Shah, Gunjal Nikita, et-al, presented an article on how to use zigbee to construct a programmable wireless bell system for schools and colleges. Software on a computer may be used to program time. The software that is used to operate the bell command is connected to a zigbee module on the transmitter side of the system. The zigbee model wirelessly transmits the signal to the receiver's zigbee. The Arduino controller processes the signal that is received at the receiver. The receiver's controller acts in accordance with the signal received from the transmitter to operate the bell. The system's key advantage is that it is wireless, allowing receiver positions to be adjusted anywhere in the target area. Increasing transmitter to receiver distance will be the focus of their future studies [8].

In 2019, AISSMS IOIT, PUNE, Ms. Khedekar Kavita dilip, and Ms. Rinku Chavan presented a paper on the construction of a system to accurately and automatically ring the bell at set times. It keeps track of actual time using an RTC (DS1307). Arduino maintains control over every function through a program, and it obtains the current time from a keypad and saves it to memory. The date and timings are shown on an LCD panel. The bell is activated by a relay for a set amount of time when the programmed time matches real time. The bell ringing time may be altered so that it can be continuously utilized [9].

A proposal presented by S.Arockia, Ranjith Kumar, R.Glarwin, M.Gowthamaraj, M.K. Vijayanainar, and G.Shunmugalakshmi is of great help in institutions where the teaching portions might last up to eight periods, including breaks. The main benefit of this project is that it successfully automates the manual process of turning on and off the college bell at the appropriate times, with a high degree of precision, at the beginning of each period. LAN is being used for this project. The same WiFi network should be used by both the Hardware and the App [10].

In 2020, A scheme was developed by Ms. Shubhshri Prakash Kumbhar and Ms. Haripriya Manikant Gavali that would take over the responsibility for ringing the bell at universities, schools, and businesses. This design employs an Atmega16 microprocessor to arrange the school's teaching, break, and exam periods, replacing the manual switching of the bell. Once we've established the time, the bell rings automatically. An automated college bell is now absolutely necessary for sake of accuracy and efficiency. Accordingly, we shall adjust the essential quantity. The fact that this method offers us the accurate time and doesn't require human intervention is its main benefit [11].

### **3. Proposed System**

The proposed system consists of ESP-32 microcontroller that supports Wi-Fi and Bluetooth, which is the main controller of the system, DS3231 RTC model which is a high-accuracy real-time clock to keep real time as a digital clock when the power goes out, as it is equipped with a 3V 2032 type battery, LCD1602 Liquid Crystal Display to display the current time in addition to the information entered into the system via Bluetooth integrated with the ESP-32, Solid State Relay SSR which is used as a high-efficiency key to operate the school bell at preset times and according to the daily lesson schedule, Push Button for entering the system configuration by pressing it at the beginning of the device operation, 2N2222 NPN transistor to drive SSR with 5V, 10K Ohm variable resistor used to control the contrast of LCD display, Printed Circuit Board (PCB) is used to include all the electronic part of the designed system, Light Emitting Diode is used to indicate that the SSR is turned On and OFF, and finally the voltage regulator (5V/3A Step Down Buck Converter) to reduce the voltage of the transformer responsible for feeding the system and which supplies the system with (9-12V DC). Fig. 1 illustrates the full block diagram of the designed system.

The proposed system mentioned above require a low cost electronic models connected together as shown in Fig. 1 to perform all system tasks.

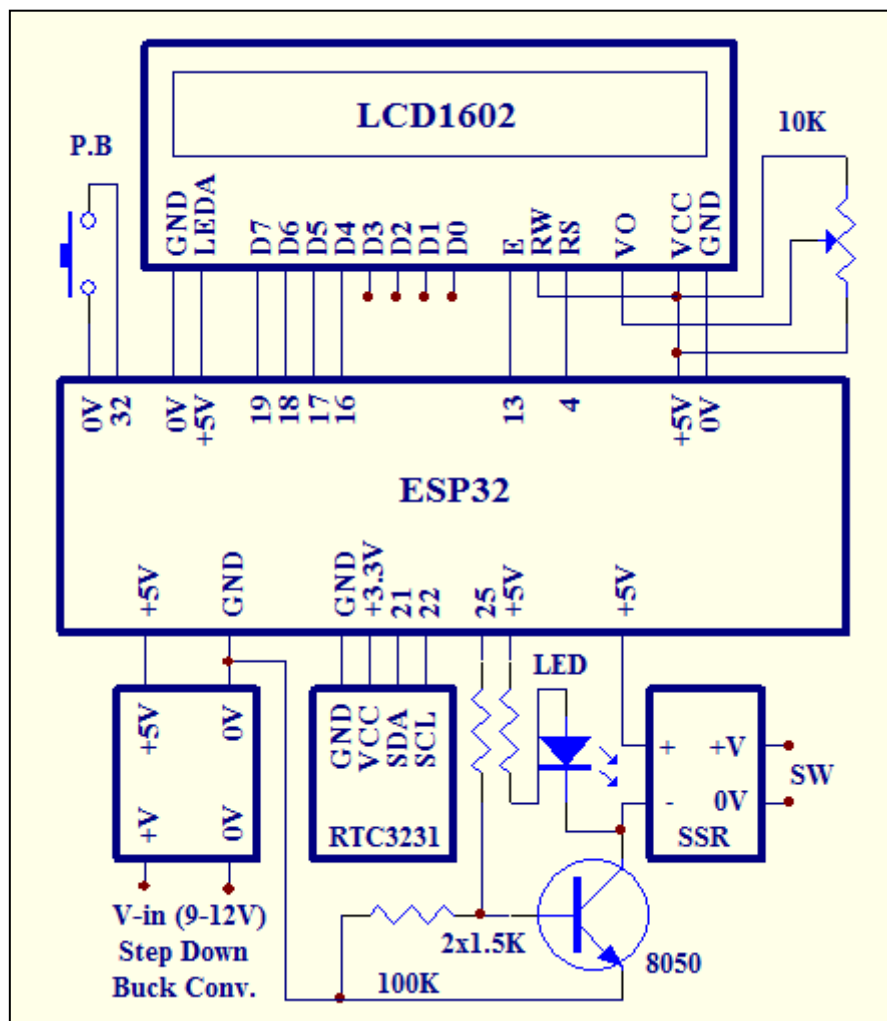
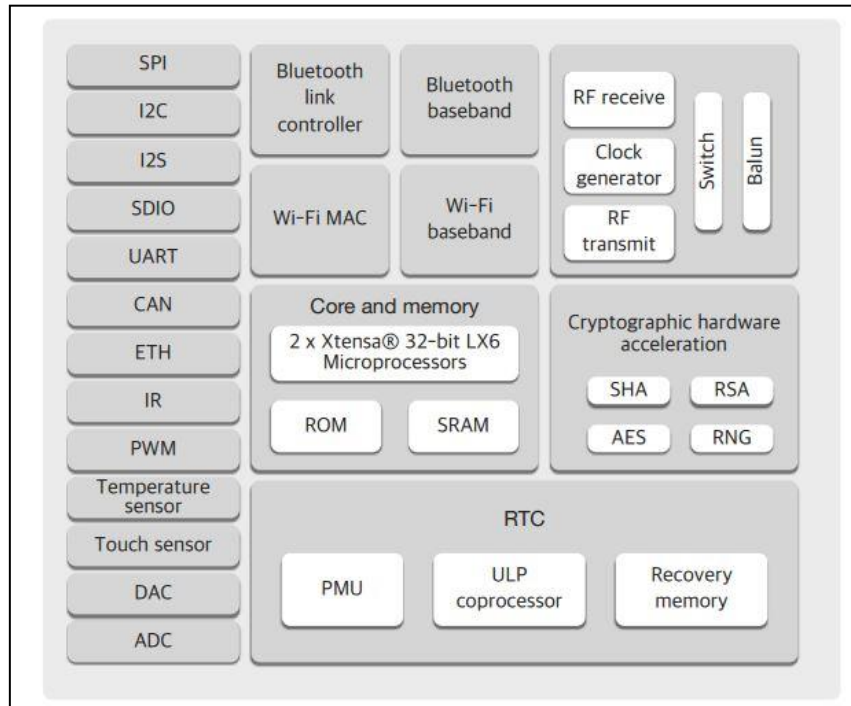

Figure 1. Full Block Diagram of the Proposed System

#### 4-1 ESP32

ESP32 is a series of low-cost, reduced-power system-on-chip microcontrollers with built-in dual-mode Bluetooth and Wi-Fi. The Tensilica Xtensa LX6 dual-core or single-core microprocessor, Tensilica Xtensa LX7 dual-core, or a mono-core RISC-V microprocessor is utilized in the ESP32 series, that has integrated antenna switches as well, RF baluns, power amplifiers, low-noise receive amplifiers, filters, and power-management modules [12]. Chinese business Espressif Systems, with headquarters in Shanghai, created and created the ESP32, which is created by TSMC using their 40 nm technology. It is the ESP8266 microcontroller's replacement. Fig. 2 shows the internal block diagram of ESP-32 microcontroller [13].



**Figure 2.** Internal Block Diagram of ESP-32

#### 4-2 DS3231 RTC

The DS3231 is a temperature-compensated crystal oscillator-equipped I2C Real time clock that is incredibly accurate. When the device's power supply is cut off, the battery backup ensures precise timekeeping. RTC keeps track of information about the hours, minutes, seconds, year, month, day, and date. The clock can run in a 12 or 24-hour configuration with an AM/PM display. I2C bidirectional bus transfers data and addresses in serial fashion [14]. DS34231 model is shown in Fig 3.



**Figure 3.** DS3231 RTC model

### 4-3 LCD1602

The LCD1602, also known as a 1602 character-type liquid crystal display, is a sort of dot matrix module that shows words, numbers, and other data. One character fills each of the 5x7 or 5x11 dot matrix slots. There is a dot pitch and a space between each pair of letters as well as between each line. The model 1602 indicates that there are two lines, each with 16 characters.

Since LCD1602 often has parallel connectors, it can control several pins at once. There are two different kinds of LCD1602 connectors: eight-port connections and four-port connections. The eight-port connection uses virtually all of the digital ports on the SunFounder Uno board. No ports will be accessible for the addition of additional sensors. Hence, for better application, the four-port connection is utilized here [15]. Fig. 4 illustrates LCD1602 Liquid Crystal Display, while Table 1 shows pin configuration of the mentioned LCD display.

**Table 1:** LCD1602 Pin Configuration

Pin	Function
VSS	connected to ground
VDD	connected to a +5V power supply
VO	to adjust the contrast
RS	A register select pin that controls where in the LCD's memory you are writing data to. You can select either the data register, which holds what goes on the screen, or an instruction register, which is where the LCD's controller looks for instructions on what to do next.
R/W	A Read/Write pin to select between reading and writing mode
E	An enabling pin that reads the information when High level (1) is received. The instructions are run when the signal changes from High level to Low level.
D0-D7	to read and write data
A	Pins that control the LCD backlight. Connect A to 3.3v.
K	Pins that control the LCD backlight. Connect K to GND.



**Figure 4.** LCD1602 Liquid Crystal Display

#### **4-4 Solid State Relay (SSR)**

PCB mounted solid state relays, also known as PCB SSR Relay, PCB mountable solid state relay, PCB mount solid state relay, PCB mounting solid state relay, PCB mount solid-state DIL (Digital Integrated Logic) relay, solid state PCB-mount relay, which are packaged with standard industry SIP (PCB SIP solid state relay) and DIP (PCB DIP solid state relay), can be used directly on the Printed Circuit Board.

The PCB SSR also has the advantages of small size, easy installation, low price, and etc. According to the output power, the housing of the PCB solid state relay can be metal or plastic. Because they generate very little heat, it is usually not necessary to install an additional heat sink.

There are two series of PCB mount solid state relay: GJ series (SIP solid state relay) and JGX series (DIP solid state relay). GJ series PCB solid state relays use Single In-line Package mounting dimensions. JGX series PCB solid state relays use Double In-line Package mounting dimensions. They can be used into application with control signal (3~32VDC, 0~10mA) and equipment load (1~8A, 5~220VDC, 220VAC/380VAC) as shown in Fig. 5 [16].



**Figure 5.** MGR 3A/380V Solid State Relay (SSR)

#### **4-5 Push Button Switch**

An electronic switch is a part of an electronic device or component that may interrupt or change the direction of a current in an electrical circuit. A common type of input "button" for electronic applications is the tactile push button switch. For temporary connections in prototypes, they can also be mounted on a PCB or a solderless breadboard. When the button is pressed, the open (disconnected) pins briefly shut for completing the circuit. Fig. 6 illustrates Push Button switch [17].



**Figure 6.** Tactile Push Button Switch

#### ***4-6 NPN Transistor (2N2222)***

A common NPN bipolar junction transistor (BJT) utilized in switching or a general-purpose low-power amplifying application is the 2N2222A. It is intended to work at fairly fast speeds and with low to medium current, low power, and medium voltage [18]. See Fig. 7.

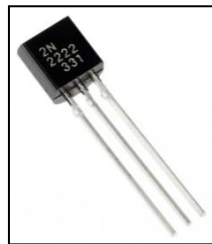
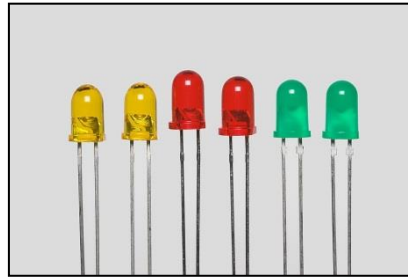

**Figure 7.** 2N2222 NPN Transistor

#### ***4-7 Light Emitting Diode (LED)***

Presently, only extremely particular projects requiring a high level of impact resistance employ this kind of LED. It is typically a more expensive alternative because of its lesser manufacturing volume when compared to other LED technologies. However, it remains a competitive alternative on the market because to its performance and exceptional durability.

In automobiles, houses, and even phones. There's a strong possibility that an LED is in the back of any electrical lighting. They come in a broad range of forms, sizes, and colors, but regardless of how they seem, they always share the same trait: They are commonly believed to improve any endeavor, and they are frequently added to unlikely things (much to everyone's satisfaction) [19]. See Fig. 8.



**Figure 8.** Light Emitting Diode (LED)

#### ***4-8 Standard 10 K $\Omega$ Potentiometer (Pot)***

A three-terminal variable resistor with manual adjustment is called a potentiometer. A resistive element has two terminals attached to either end, and a third terminal is linked to a sliding contact recognized as a wiper that moves over the resistive element. The potentiometer's output voltage is determined by the wiper's position [20]. See Fig. 9.

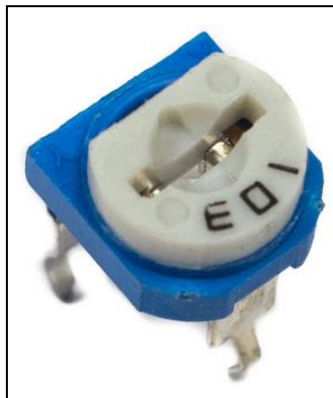

**Figure 9.** Standard 10 K $\Omega$  Potentiometer (Pot)

#### ***4-9 Printed Circuit Board (PCB)***

Printed circuit boards, commonly known as PWBs or printed wire boards, are a type of media utilized to securely link electronic components to one another in electrical and electronic engineering. It looks like a laminated sandwich construction with insulating and conductive layers, with each of the conductive layers having a pattern of traces, planes, and other features (such as wires on a flat surface) created from one or more copper sheet layers laminated onto and/or between sheet layers of a non-conductive substrates. In order to both electrically connect and physically bind electrical components to it, conductive pads on the outer layers may be fastened to in the shape intended to receive the component's terminals by soldering. Another manufacturing process adds vias: plated-through holes that allow interconnections between layers [21]. See Fig. 10.

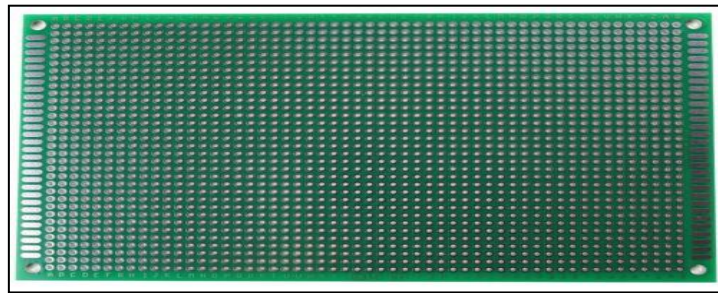

**Figure 10.** Printed Circuit Board (PCB)

#### **4-10 9V Power Supply**

Is a top-notch AC to DC 9V 650mA "wall wart" wall power supply. These power supply are switch mode, therefore the output is regulated to 9V and the maximum output current is about (1000mA) [22].

These will power most projects that don't require more than 1000mA of current as shown in Fig. 11.



**Figure 11.** 9V Power Supply

#### **4-11 DC-DC 3A 5V-12V 24V To 9V Step-down Power Supply Module**

With input polarity reversal protection, output overvoltage protection, and short circuit protection, this tiny DC-DC step-down voltage converter module accepts 5-24 volts of input voltage and produces 9 volts of output voltage. It makes maximum use of your input power by utilizing rectification technology synchronously to assure ultra-high power conversion of up to 97.5% [23]. See Fig. 12.

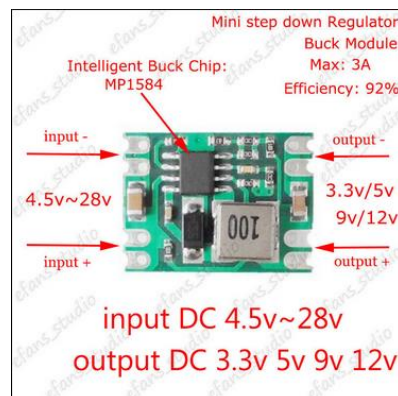

**Figure 12.** DC-DC 9-12V to 3A 5V Step-down Power Supply Module

#### 4. Implementation and Results

Fig. 13 illustrates the complete circuit implementation of the designed system including all hardware components mentioned above using single PCB board.

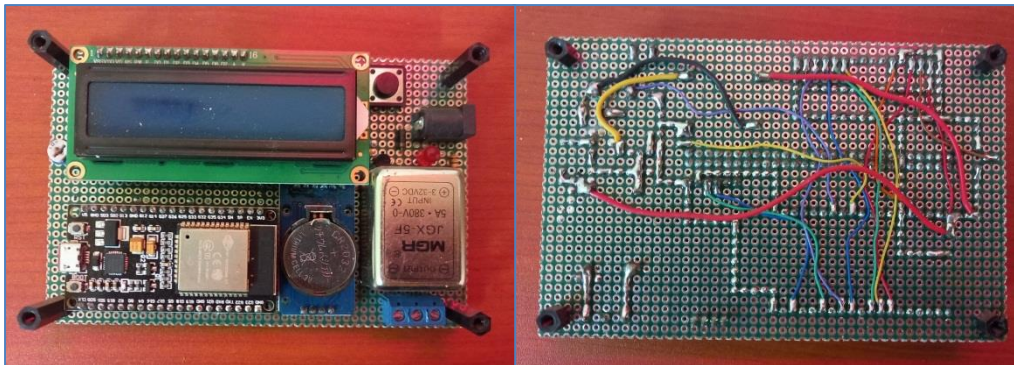

**Figure 13.** Hardware System Implementation

First, the device should configure to connect to the Internet using a proper SSID and PASSWORD of Router via Bluetooth using “Serial Bluetooth Terminal” application for Android mobile phone as shown in Fig. 14.



**Figure 14.** Serial Bluetooth Terminal application

Table 2 illustrates all command used to configure the design system using “Serial Bluetooth Terminal” application via ESP-32 Bluetooth.

**Table 2:** System Commands

Command No.	Command	Meaning
1.	*8421*CHPAS*new password#	Change system password
2.	*8421*SSID*net ssid#	Change net SSID
3.	*8421*PASS*net password#	Change net password
4.	*8421*OFFS*time offset#	Change NTP offset
5.	*8421*TSIZE *timetable size#	Define timetable size
6.	*8421*TABLE*00*08:30# *8421*TABLE*01*09:15# ---	Entering Timetable
7.	*8421*DELAY*5000#	Ring On Delay
8.	*8421*CLEAR#	Clear Timetable

Fig. 15 illustrates the operation for configuring SSID via Bluetooth using Serial Bluetooth Terminal. The push button should press before turning device ON to enter configuration mode.



**Figure 15.** Configuring SSID

Fig. 16 illustrates the operation for configuring PASSWORD via Bluetooth using Serial Bluetooth Terminal.



**Figure 16.** Configuring PASSWORD

Fig. 17 shows trying to connect to the Internet, Connected, and RTC synchronized.



**Figure 17.** trying to connect to the Internet, Connected, and RTC synchronized

Fig. 18 illustrates the operation for entering the time for starting the first lecture using Serial Bluetooth Terminal as an example.



**Figure 18.** Entering the Time for starting the First Lecture

Fig. 19 illustrates the operation for entering the time for ending the first lecture using Serial Bluetooth Terminal as an example.



**Figure 19.** Entering the time for ending the first lecture

Fig. 20 illustrates the displaying the actual time of the RTC on Liquid Crystal Display (LCD).



**Figure 20.** Displaying the actual time of the RTC on Liquid Crystal Display (LCD)

When the time was (8:30 AM), which is stored as the first time in the timetable before, the bell rang in 5 seconds and SSR turned ON and LED is goes on as shown in Fig. 21.



**Figure 21.** Bell rang at (8:00 AM)

At (9:15 AM), which is stored as the second time in the timetable before, the bell rang in 5 seconds and SSR turned ON and LED is goes on as shown in Fig. 22.



**Figure 22.** Bell rang at (9:15 AM)

Using the same steps above, all commands mentioned in Table 1 can be entered to the system like (Change System Password, Change NTP offset, Define timetable size, Ring-On Delay, and Clear Timetable). Note that the maximum size of Timetable is 100.

## 5. Conclusion

Through the results of the School Bell Control System, the results indicated the importance of the device for this purpose, as well as the high accuracy in timing as it is connected to the server "ch.pool.ntp.org", as the system does not need to calibrate the clock and adjust the very small error as it was also mentioned in the abstract that the error rate was  $\pm 40$  seconds per year in the absence of the Internet. As well as ease of dealing with the system in terms of configuration and operation.

## 6. Acknowledgment

The authors would like to thank the University of Mosul/ College of Computer Sciences and Mathematics for their provided facilities, which helped to improve the quality of this work.

## References

- [1] Syed Naveed Uddin, Mohd Omer Nawaz, et-al, “Automatic School Bell with User defined Time Schedule”, *Electronics and Instrumentation Engineering, Website: [www.ijareeie.com](http://www.ijareeie.com), Vol. 6, Issue 2, February 2017*
- [2] Burgoji Santhosh Kumar, “Implementation of automatic college bell system using arduino”, *International journal of current engineering and scientific research (IJCESR), ISSN (print): 2393-8374, (Online): 2394-0697, Volume-5, Issue-4, 2018*
- [3] Khairul Abdi Azizi , Arnes Sembiring, Mili Arfisyari, “Design and Build an Automated School Bell System Using Voice-Based IoT”, *International Journal Of Health, Engineering And Technology (IJHET), Volume 1, Number 3, September 2022, Page. 383 - 392*
- [4] Tria Hadi Kusmanto, Bramantara Yudha, “Utilization of arduino uno r3 and rtc ds3231as automatic school bell”, *nternational conference on community service programme, lembaga penelitian dan pengabdian kepada masyarakat, Universitas Pгри Semarang, ISBN: 978-623-91160-2-6, 2020*
- [5] Shweta Butoliya, Nupur Shal, Snehal Girhepunje, Aakanksha Rannaware,Prerna Baddalwar, Vaishali Badwe “Microcontroller Based Automatic College Bell With Monitoring System” *Zx Lee, 4x4 matrix keypad, Personal blog on Electronics and Programming, 24-07-2013. Web. Accessed on 01-02-2017.*
- [6] Henry Ohiani Ohize<sup>1</sup>, Elizabeth Nonye Onwuka<sup>2</sup> and Ahmed Ibrahim “Design of Microcontroller-Based Automatic School Bell” *Web. Accessed on 12-01-2017. <https://www.arduino.cc>*

- [7] D. K. Shah, Gunjal Nikita, et-al, “Automatic wireless college bell system using zigbee”, 2019 JETIR May 2019, Volume 6, Issue 5, [www.jetir.org](http://www.jetir.org) (ISSN-2349-5162)
- [8] *Ms. Khedekar Kavita dilip, Ms. Rinku Chavan, AISSMS IOIT, PUNE*, “Arduino Controller Automatic College Bell System”, JASC: Journal of Applied Science and Computations, ISSN NO: 1076-5131, Volume VI, Issue V, May/2019, Page No:2994
- [9] S.Arockia Ranjith Kumar, R.Glarwin, et-al, “ Iot Based Automatic College Gong”, International Journal of Scientific & Technology Research Volume 9, ISSUE 03, March 2020, ISSN 2277-8616
- [10] Ms. Shubhshri Prakash Kumbhar<sup>1</sup>, Ms. Haripriya Manikant Gavali, et-al, “Implementation of Automatic College/Industry Bell System using Visual Studio & ATMEGA 16 Microcontroller”, International Journal for Research in Applied Science & Engineering Technology (IJRASET), ISSN: 2321-9653; IC Value: 45.98; SJ Impact Factor: 7.429, Volume 8 Issue XII Dec 2020- Available at [www.ijraset.com](http://www.ijraset.com)
- [11] Shabnum Rasool Shaikh, Snehal Suryakant Kale, et-al, “ Arduino based Real Time Clock with Ringing of Bell and National Anthem”, International Journal on Recent and Innovation Trends in Computing and Communication, ISSN: 2321-8169, Volume: 6 Issue: 6, 33 – 35, 2018
- [12] *Espressif*, "Espressif Announces the Launch of ESP32 Cloud on Chip and Funding by Fosun Group". *Espressif Systems*. 2016-09-07. Retrieved 2021-03-29.
- [13] *Espressif*, "ESP32-S2\_datasheet" (PDF). *Espressif*. 2021-06-02.
- [14] Maxim Integrated Products Inc.,”DS3231 Extremely Accurate I2C-Integrated RTC/TCXO/Crystal” DS3231 Datasheet, 2015.

- [15] <https://www.sparkfun.com/datasheets/LCD/ADM1602K-NSW-FBS-3.3v.pdf>
- [16] <https://electronics.huimultd.com/Product/Solid-State-Relay/PCB-Mount-SSR/JGX-Series/>
- [17] <https://alphatronic.lk/product/tactile-push-button-switch-12-x-12-x-8mm/>
- [18] <https://www.pcboard.ca/2N2222-NPN-Transistor>
- [19] <https://learn.sparkfun.com/tutorials/light-emitting-diodes-leds/all>
- [20] <https://potentiallabs.com/cart/10k-pot>
- [21] "What Is a Printed Circuit Board (PCB)? - Technical Articles". *www.allaboutcircuits.com*. Retrieved 2021-06-24.
- [22] [https://www.thomann.de/gr/strymon\\_power\\_supply\\_9v\\_dc.htm](https://www.thomann.de/gr/strymon_power_supply_9v_dc.htm)
- [23] <https://www.ebay.com/itm/191927096114>