

## **Analysis and Testing of the Expansion Tank in the Rectangular Flow Channel FASSIP-04 Ver.0**

**Dwi Yuliaji<sup>1</sup>, Roy Waluyo<sup>1</sup>, Alimudin<sup>1</sup>, A. H. Hendrawan<sup>1</sup>, Hawa Bt Hishamuddin<sup>2</sup>, Mulya Juarsa<sup>3</sup>**

<sup>1</sup>Program Studi Teknik Mesin, Universitas Ibn Khaldun Bogor, Indonesia,

<sup>2</sup>Department of mechanical & Manufacturing Engineering-UKM, Malaysia, <sup>3</sup>National Research Agency (BRIN), Indonesia

**Abstract.** The expansion tank in the FASSIP-04 Ver.0 Rectangular Loop functions as a reducer of pressure fluctuations during the natural circulation flow. The expansion tank function cannot work optimally if there is a leak in the welding area or the material structure is not good. So the purpose of the research conducted is to obtain a stable pressure value and material strength value. The research was conducted using experimental method and finite element analysis simulation. Experiments were carried out by applying pressure to the expansion tank from 1.5 bar to 4 bar and held for up to 1 hour. Then simulations were carried out based on variations in the input pressure given from 4 bar, 125 bar, and 154 bar. Experimental results at input pressures of 1.5 bar, 2 bar, 2.5 bar, 3 bar, 3.5 bar, and 4 bar show the pressure difference is 0.00 bar, 0.01 bar, 0.01 bar, 0.00 bar, -0.01 bar, 0.02 bar in respectively. Meanwhile, simulation results at input pressures of 4 bar, 125 bar, and 154 bar show the maximum stress values received by the expansion tank are  $1.090 \times 10^7$  N/m<sup>2</sup>,  $3.405 \times 10^8$  N/m<sup>2</sup>,  $4.195 \times 10^8$  N/m<sup>2</sup>, respectively. Based on the analysis results, it can be concluded that the expansion can be used for experiments.

**Keywords.** Expansion Tank, FASSIP-04 Ver.0, Natural Circulation, Pressure, Material Strength

### **Introduction**

According to Radita (2018), nuclear power plants (NPPs) are one of the power generation systems that utilize alternative energy sources and are being widely developed by advanced countries. This is because NPPs generate a significant amount of electrical energy compared to other power plants while requiring a relatively small amount of fuel. The commonly used fuel for NPPs is Uranium-235. The nuclear fission reaction of Uranium nuclei produces a tremendous amount of heat energy (BRIN-BATAN, n.d.). The heat energy generated from the nuclear fission reaction is used to heat or boil water, and the resulting heat is then transferred to another channel, causing the water to turn into steam (Jantan, 2018). The utilization of nuclear energy as a power source is an essential part of the national electricity program in various countries, particularly to anticipate the depletion of fossil fuel energy sources (Tjipta, 2016).

Passive cooling system is a mechanism to cool down the reactor heat triggered by the indication of accident disturbance (Harto, 2010). In principle, passive safety systems utilize the physical properties or conditions of an object/material as a system that can maintain the safe

operation of a nuclear reactor. The passive cooling system is a heat removal system that does not require electrical power. The nuclear reactor coolant no longer uses electricity as a pump to circulate water for the cooling system (Mulya Juarsa, 2014). The performance of a passive thermal-hydraulic system is usually influenced by initial conditions, material usage, layout, and uncertainties such as heat transfer coefficients, pressure drop coefficients, and critical parameters of the nuclear reactor. These factors are used to describe the behavior of the passive system (Burgazzi, 2006). Based on qualitative and deterministic analysis, there are determining parameters for the performance of safe decay heat removal in a passive system, such as pressure drop, heat transfer, surface area, decay heat, initial air flow, SCRAM delay, damper opening delay, air inlet temperature, initial power, initial sodium temperature, steady-state core flow, and fuel conductivity (Mathew S.T, 2011).

Natural circulation (NC) is a simulation facility of a passive system used to investigate natural circulation phenomena for mastering the capability of a passive cooling system. Natural circulation phenomena are based on the laws of physics, where circulation can occur naturally without the use of electrical energy or other inputs (Juarsa, Purba, Kusuma, Setiadipura, & Widodo, 2014). The initial study of such flow patterns began with the Rayleigh analysis, which discusses the stability of fluids when they come to rest momentarily and start moving due to temperature gradient towards the force of gravity (J. Lim, 2014). One example of natural circulation (NC) and nuclear reactor safety and security systems is found in the Indonesian government, such as at the National Research and Innovation Agency (BRIN). Researchers at BRIN have conducted extensive research and development on nuclear power plant safety technology. For example, at the Nuclear Reactor Technology Research Center (PRTRN) and the Nuclear Energy Research Organization (ORTN), they have been developing passive cooling systems for nuclear power plant thermal management, utilizing experimental facilities such as the Rectangular Flow Channel FASSIP-01, Test Loop FASSIP-02, FASSIP-03 NT Loop, PASCONEL Facility, and Rectangular Flow Channel Simulation Facility for Passive System (FASSIP 04-Ver.0). One interesting topic of research is the expansion tank, which is one of the components of the Rectangular Flow Channel FASSIP-04 Ver.0.

The research is focused on analyzing and testing the expansion tank, considering its material strength and functionality, to ensure it becomes a safe component for use in the Rectangular Flow Channel FASSIP-04 Ver.0. The expansion tank is a pressure vessel that will be installed in the configuration of the Rectangular Flow Channel Simulation Facility for Passive System 04-Ver.0 (FASSIP 04-Ver.0). The expansion tank is used in the Rectangular Flow Channel FASSIP-04 Ver.0 to maintain pressure, especially in the loop, where it will regulate the water pressure entering the tank to dampen fluctuations by approximately 1 atmosphere. Therefore, the expansion tank will be the subject of research.

### **Method**

The material used in the analysis and testing of the expansion tank for the Rectangular Flow Channel FASSIP-04 Ver.0 is AISI 1020 steel. AISI 1020 steel is a popular type of low carbon steel. It has a chemical composition with a carbon content ranging from approximately 0.18% to 0.23% and a manganese content ranging from approximately 0.30% to 0.60%.

**Table 1.** Mechanical Properties of AISI 1020 Steel (Source:(WorldMaterial, 2018))

Mechanical Properties	Metrik
Hardness, <i>Brinel</i>	207
Hardness, <i>Knoop</i>	180
Hardness, <i>Rockwell B</i>	80
Hardness, <i>Vickers</i>	160
Attraction, <i>Ultimate</i>	420 Mpa
Attractiveness, <i>Yield</i>	351 Mpa
Elongation at Break	25%
Modulus of elasticity	190-210 Gpa
Poisson ratio	0,30
Charpy Impact	70 J
Shear modulus	70-80 Gpa

The equations used in this research to obtain the maximum pressure, longitudinal pressure, and tangential pressure occurring in the expansion tank, as referenced from (Aziz, Hamid, & Hidayat, 2014), are formulated as follows:

$$P_{maks} = \frac{\sigma_t \times E \times t}{R_d + (0,6 \times t)} \dots\dots\dots(1)$$

Keterangan:

- $\sigma_t$  = Voltage izin material ( $N/m^2$ )
- $t$  = Bold tabung (m)
- $R_d$  = Fingers diameter in (m)
- $E$  = *Joint efficiency*
- $P_{maks}$  = Pressure maksimal ( $N/m^2$ )

$$\sigma_l = \frac{P \times R_d}{2 \times t} \dots\dots\dots(2)$$

Keterangan:

- $\sigma_l$  =Voltage longitudinal ( $N/m^2$ )
- $p$  =Pressure planning ( $N/m^2$ )
- $R_d$  = Fingers diameter in (m)
- $t$  = Bold (m)

$$\sigma_c = \frac{P \times R_d}{t} \dots\dots\dots(3)$$

Keterangan:

- $\sigma_{tang}$  = Voltage tangensial ( $N/m^2$ )
- $p$  = Pressure planning ( $N/m^2$ )
- $R_d$  = Fingers diameter in (m)
- $t$  = Bold (m)

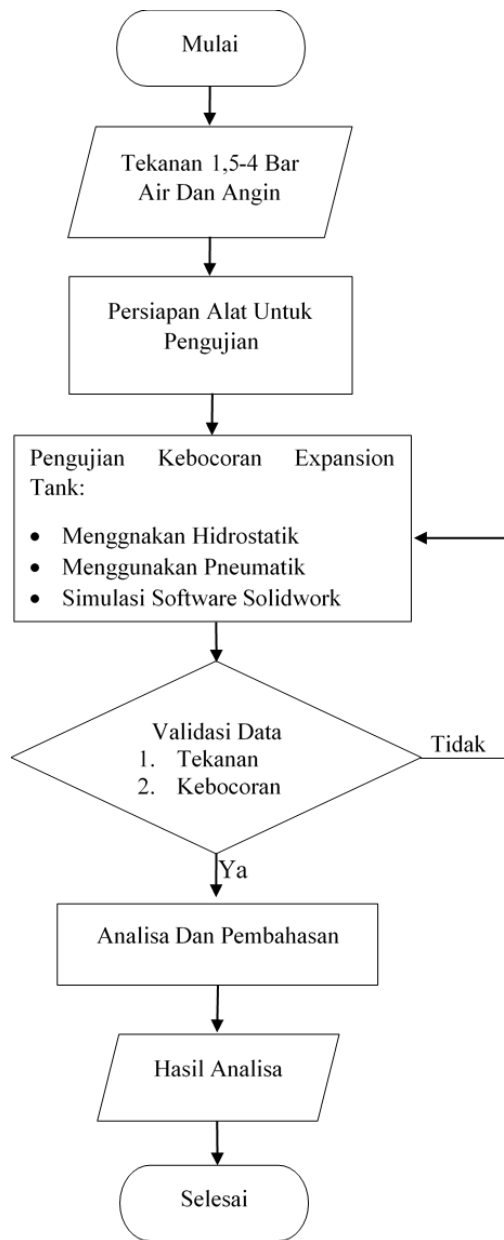

**Figure 1.** Research Flow Chart

The following is a picture of the hydrostatic testing scheme carried out in the experiment, can be seen in the following figure:

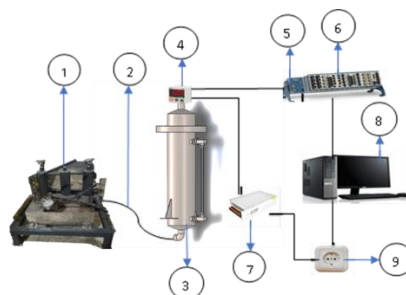

**Figure 2.** Hydrostatic Testing Scheme

Hydrostatic pump – hose – *expansion tank* – *pressure sensor* – *Ni (National Instrumental)* – computer – socket

## Results and discussion

### Calculation Results

As for some calculations that can be sought from this test are as follows:

1. Maximum working pressure

$$P_{maks} = \frac{\sigma_t \times E \times t}{R_d + (0,6 \times t)}$$

$$P_{maks} = \frac{\left(5,4 \times \frac{10^8 \text{ N}}{\text{m}^2}\right) \times 0,75 \text{ N/m}^2 \times 0,0066 \text{ m}}{0,063 \text{ m} + (0,6 \times 0,0066 \text{ m})}$$

$$P_{maks} = \frac{2673000}{0,06696}$$

$$P_{maks} = 3,991 \times 10^7 \text{ N/m}^2$$

The maximum working pressure that occurs is  $3,991 \times 10^7 \text{ N/m}^2$

2. Longitudinal Pressure

$$\sigma_l = \frac{P \times R_d}{2 \times t}$$

$$\sigma_l = \frac{4 \times 10^5 \text{ N/m}^2 \times 0,063 \text{ m}}{2 \times 0,006 \text{ m}}$$

$$\sigma_l = \frac{25200}{0,012}$$

$$\sigma_l = 2,1 \times 10^6 \text{ N/m}^2$$

The longitudinal pressures that occur are  $5,4 \times 10^6 \text{ N/m}^2$

3. Tangesial Pressure

$$\sigma_c = \frac{P \times R_d}{t}$$

$$\sigma_t = \frac{4 \times 10^5 \text{ N/m}^2 \times 0,063 \text{ m}}{0,006 \text{ m}}$$

$$\sigma_t = \frac{25200}{0,006}$$

$$\sigma_t = 4,2 \times 10^6 \text{ N/m}^2$$

Pressure tangesial yang terjadi adalah  $4,2 \times 10^6 \text{ N/m}^2$

### Experimental Results

The experiment was carried out using hydrostatic pressure for 3600 seconds and given a pressure of 1.5 bar to 4 bar with 3 tests in each bar. The pressure can be increased according to the test matrix if no abnormal phenomena occur in the test.

1. Testing using hydrostatic pressure

**Table 3.** Average result of 3 hydrostatic pressure tests

Pressure [Bar]	Waktu [s]	Pressure awal [Bar]	Pressure akhir [Bar]	Pressure rata – rata [Bar]	Rata-rata Selisih Pressure $\Delta P$ (bar)
1,5	3600	1,53	1,53	1,53	0,00
2,0	3600	2,03	2,02	2,03	0,00
2,5	3600	2,52	2,51	2,51	0,01
3,0	3600	3,00	3,02	3,01	-0,01
3,5	3600	3,57	3,51	3,56	0,03
4,0	3600	4,10	4,15	4,13	-0,02

Testing using hydrostatic pressure on the expansion tank that has been carried out, on each bar there is no significant pressure drop, because the *expansion tank* does not experience leakage and here is one graph of the test results :

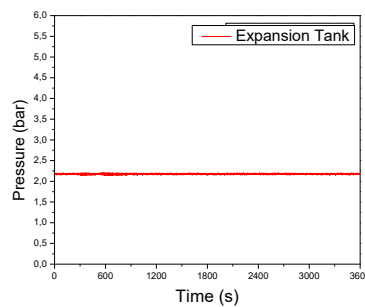

**Figure 3.** Test Charts

From the test results at the hydrostatic pressure above, with a holding time of 3600 seconds. A graph is made with the result of a small deviation rate, shown in the following figure:

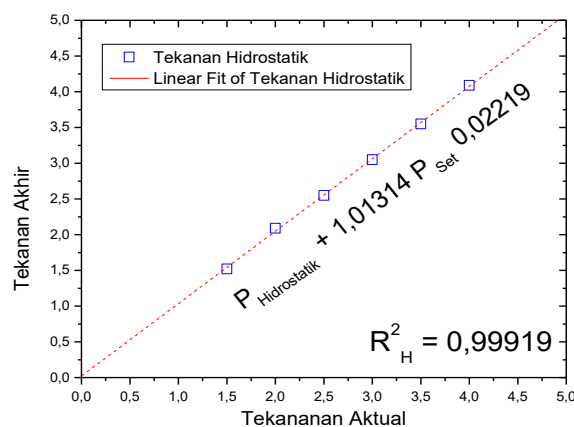

**Figure 6.** Comparison graph of pneumatic and hydrostatic pressure testing

The graph shows that the deviation value is low or small, which indicates a low leakage rate. This indicates that the expansion tank on the FASSIP-04 Ver.0 Rectangular Strand is safe to use at pressures between 1.5 bar and 4 bar. With low deviations, expansion tanks keep pressure consistently within the desired range, with little significant variation or fluctuation. This is a good indicator that the pressure handling system is effective and reliable, and is able to maintain a stable pressure and as needed. These results can be guaranteed to be accurate because the value on the graph is 0.99919 out of 1, meaning that the value can be said to be almost perfect.  $R^2R^2$

### Simulation Results

The simulation was carried out based on variations in pressure inputs ranging from 4 bar, 125 bar, and 154 bar. You can see the maximum voltage results from the following simulation:

#### 1. Simulasi Voltage (4 bar)

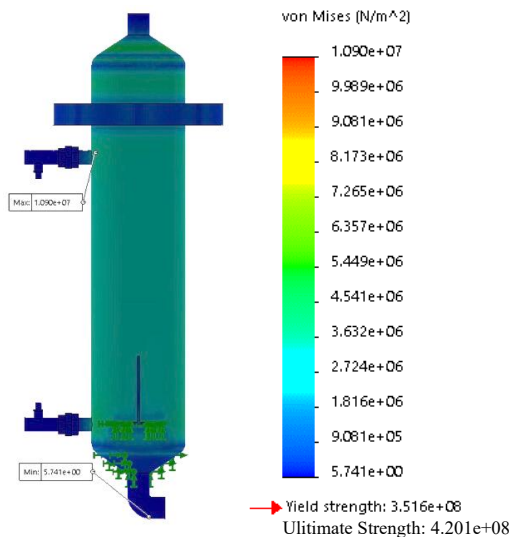

**Figure 7.** Voltage (4 bar)

The results of the stress simulation above show the value of stress distribution in the analyzed structure. The maximum voltage observed is 1,090°C, which occurs in several specific regions. The maximum stress value is far below the yield strength value of the material, which is 3,516. This indicates that the structure has sufficient safety factors against structural deformation or failure. Although some areas may experience high voltage, but the overall structure remains within safe strength limits  $\times 10^7 N/m^2 \times 10^8 N/m^2$ .

1. 2. Simulated Voltage (125 bar)

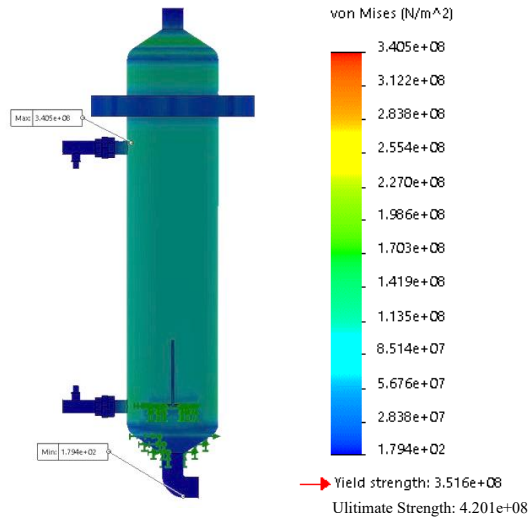

**Figure 8.** Voltage (125 bar)

In this stress simulation, we can see the stress distribution in the structure being analyzed. The maximum voltage observed is 3,405 which is  $\times 10^8 N/m^2$  below the yield strength value of the material, which is 3,516. This indicates that the structure has a sufficient safety factor against deformation. Although some areas may experience high voltage, but the overall structure remains within safe strength limits  $\times 10^8 N/m^2$ .

2. Simulated Voltage (154 bar)

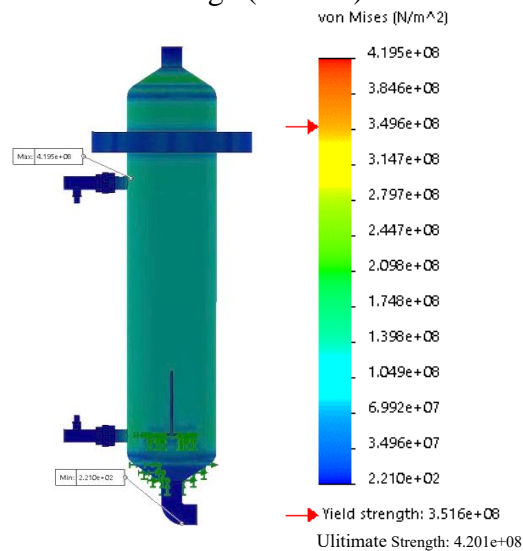

**Figure 9.** Voltage (154 bar)

The results of stress simulation show the stress distribution in the analyzed structure. The maximum voltage observed is 4,195,  $\times 10^8 N/m^2$  which is below the material's ultimate strength of  $4,201 \times 10^8 N/m^2$ . This indicates that the structure has sufficient safety factors

against structural deformation or failure. Although some areas may experience high stress, overall the structure remains within safe strength limits.

## Conclusion and recommendation

### Conclusion

Based on the results of hydrostatic testing, it can be concluded that the FASSIP-04 Ver.0 Rectangular Strand series shows good quality and is suitable for use. There are no leaks in the circuit even at a maximum pressure of 4 bar. This indicates that the range is reliable and meets safety and reliability requirements. Pneumatic and hydrostatic tests have proven that the FASSIP-04 Ver.0 Rectangular Strand circuit can function properly and is able to withstand the pressure exerted.

And for the results of stress simulation, it can be concluded that stress simulation reveals the stress distribution in structures with maximum stress below the yield strength of the material, showing adequate safety factors against structural deformation or failure, therefore *expansion tanks* can be used for experiments on the FASSIP-04 Ver.0 Rectangular Strand circuit.

### Suggestion

It is recommended to test with variable pressure of more than 5 Bar, you can replace the supporting material with a better one, such as replacing thread connections, taps, faucets and others.

1. It is recommended that for research on this topic, it can analyze the strength of welded joints.

## References

- [1] Aziz, A., Hamid, A., & Hidayat, I. (2014, Februari). *Perancangan bejana tekan (Pressure Vessel) untuk separasi 3 fasa*. Diambil kembali dari Google Scholar: <https://core.ac.uk/download/pdf/291842572.pdf>
- [2] BRIN-BATAN. (t.thn.). *pengenalan pembangkit listrik tenaga nuklir*. Diambil kembali dari BRIN-BATAN: <https://www.batan.go.id/index.php/id/infonuklir/pltn-infonuklir/generasi-pltn/924-pengenalan-pembangkit-listrik-tenaga-nuklir>
- [3] Burgazzi. (2006). Thermal Hydraulic Passive System Reliability Based Design Approach. *Reliability Engineering and System Safety*, 1250-1257.
- [4] Harto, d. W. (2010). Reactor Inovatif Molten Salt (IMSR) Dengan Sistem Keselamatan Menyeluruh.
- [5] Hermawan, A. Edi Marzuki, Dwi Yuliaji & Mulya Juarsa. (2019). ANALYSIS HEATING CAPABILITY IN HEATER SECTION BASED ON ALTERATION OF UNTAI USSA FTS-01. *Prosiding SNTTM XVIII*, 1-7. Diambil kembali dari <http://prosiding.bkstm.org/prosiding/2019/KE33.pdf>
- [6] indo-makmur.com. (2020, 08 17). *STAINLESS STEEL 304: KOMPOSISI, PROPERTI, KELEBIHAN, DAN JENIS*. Diambil kembali dari PT. INDOMAKMUR INTI LESTARI: [https://www.indo-makmur.com/blog/blog\\_detail/stainless-steel-304-komposisi-properti-kelebihan-dan-jenis](https://www.indo-makmur.com/blog/blog_detail/stainless-steel-304-komposisi-properti-kelebihan-dan-jenis)
- [7] J.Lim, J. S. (2014). Assesment of Passive Safety Performance Under Gravity Driven Cooling System Drain LineBreak Accident. *Progress and Nuclear Energy*, 136-142.

- [8] Jantan. (2018). *mengenal pembangkit listrik tenaga nuklir*. Diambil kembali dari Onilen .
- [9] Juarsa, M., Purba, J. H., Kusuma, H. M., Setiadipura, T., & Widodo, S. (2014). Preliminary Study on Mass Flow Rate in Passive Cooling Experimental Simulation During Transient Using NC-Queen Apparatus. *Atom Indonesia Vol. 40 No. 3*, 141 - 147.
- [10] Mathew S.T, d. (2011). Passive System Rebiability Analys Using Response Conditioning Method With An Aplication To Failure Frequeny Estimation Of Decay Heat Removal Of Pfbr. *Nuclear Engineering and Design*, 2257-2270.
- [11] Mulya Juarsa, d. (2014). Preliminary Study On Mass Flow Rate In Passive Cooling Experimental Simulation During Transient Using Nc-Queen Apparatus. *National Nuclear Energi Agency Atom Indonesia*, 40, 141-147.
- [12] Radita, A. (2018). Studi Keselamatan Pembangkit Listrik Tenaga Nuklir. *SINERGI*, 17-23.
- [13] Tjipta, S. (2016, Januari). Pembangunan Pembangkit Listrik Tenaga Nuklir (PLTN) Menopang Kebutuhan Eenergi Listrik Nasional. *Seminar Nasional TEKNOKA\_FT UHAMKA*, 162-170.
- [14] W. E., H. I., & M. A. (2021). *Fisika Dasar*. Guepedia.com.
- [15] WorldMaterial. (2018). *The World Material*. Diambil kembali dari <https://www.theworldmaterial.com/astm-sae-aisi-1020-carbon-steel/>