

## **Analysis an optical communications system by using Optisystem program to transfer data over various distances**

**Dr. Hasan J. Hasan**

**Department of Science, College of Basic Education, University of Sumer, 64005, Riffae, IRAQ**

[hasan.jaber@uos.edu.iq](mailto:hasan.jaber@uos.edu.iq)

[mktbshbkh@gmail.com](mailto:mktbshbkh@gmail.com)

**Abstract.** The transmission of data over long distances is a big challenge in the telecommunications industry. One way to achieve this is to use different wavelengths of light. In this article a comparison of wavelengths has been made to analysis of long-distance data transmission using three different wavelengths: 1625 nm, 1550 nm, and 810 nm. The purpose is to determine the most appropriate wavelength for transmitting data over distances from 60 km to 140 km, with increments of 20 km for each test. The rating is based on the performance of each wavelength in terms of signal quality, data integrity, and overall transmission efficiency.

To attain this, a comprehensive trial setup is employed. The investigational framework involves transferring data signals at every wavelengths over an optical fiber, and simulating altered transmission distances in the definite range. Key factors such as signal strength, Q. factor and bit error rate (BER) are wisely observed and analyzed. The obtained results show distinct features for each wavelengths with esteem to long-distance data transmission over the experimental usage in the simulation application for these wavelengths then examining the above factors.

**Keywords:** Optisystem, wireless , fibere optics ,Q. factor , transferring of data, simulation of wireless

### **1. Introduction**

The significance of data transmission by fiber optics has been growing in contemporary society, as communication networks have become integral to daily existence. The increasing need for efficient, dependable, and protected transfer of data has prompted the emergence of diverse technologies designed to assist this procedure. Optical fiber has emerged as a highly promising technology for the transport of data across great distances [1].

Fiber-optic communications use light to transmit data over long distances through flexible and small wires made of glass or plastic. This method is faster than traditional copper cables, and the signal doesn't easily deteriorate. Because of this, it's an excellent option for many applications including the internet and telephones.

In comes Opti System, a design tool that optimizes optical communication networks so large volumes of data can move quickly.

Selecting the right medium for transmission is crucial when creating an information highway. Optical fiber is favored because it performs great over long distances with high bandwidth and minimal signal loss. Engineers may create systems that can efficiently transmit vast volumes of data by employing modeling techniques to analyze the performance. An electrical signal must be transformed into an optical signal before it can be transmitted across an optical fiber. OptiSystem provides a comprehensive selection of lasers and modulators, two essential building blocks for any radio transmitter.

An electrical signal must be transformed into an optical signal before it can be transmitted across an optical fiber. OptiSystem provides a comprehensive selection of lasers and modulators, two essential building blocks for any radio transmitter. Upon arrival at its destination, the optical signal is converted into an electrical signal through optical fiber. The receiver is designed to take in the optical signal and transform it into an electrical signal that can be read and interpreted by a computer. When creating a receiver, Opti System provides a broad variety of essential tools, including detectors and amplifiers.[4].

One of the primary obstacles encountered in the transmission of large-scale data is to the considerable presence of noise and distortion that may arise during the process. The OptiSystem software facilitates the simulation of noise and distortion impacts on the optical signal, as well as the development of devices capable of mitigating these effects.[5].

## 2. Aim of study:

This study aims to use three windows of wavelengths used in communications and compare them in terms of the quality of data transmission over different distances, by measuring Q-Factor and Bit Error Rate (BER).

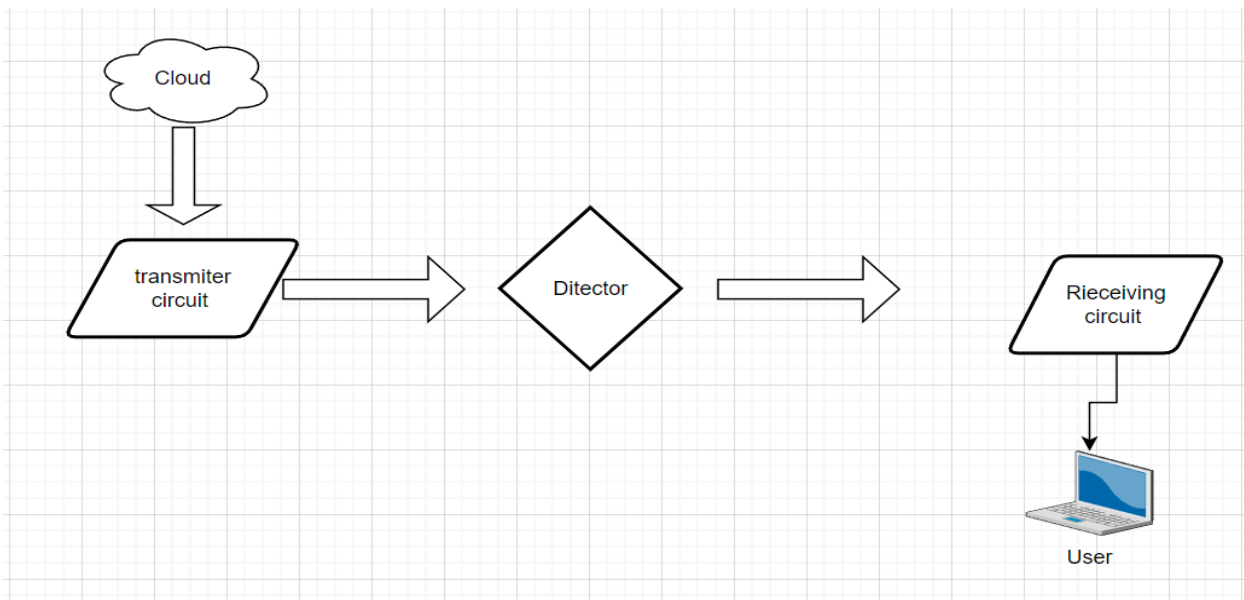

Fig. 1 Diagram for data transfer, receive system

### 3. The parts of the circuit:

This circuit consist of three main parts:

#### 3.1 The transmitter unit consists of four parts

##### 1- Pseudo-Random Bit Sequence Generator

The Pseudo Random Bit Sequence (PRBS) generator serves a specific purpose within the context of the application.

The subject matter is located within. The main use of OptiSystem is the generation of digital data patterns that emulate the transfer of real-world data through optical communication networks. It produces a deterministic bit sequence that emulates the characteristics of random data while adhering to a predetermined pattern.

The primary function of the PRBS generators within the OptiSystem application is to offer a controllable and replicable means of generating pseudo-random data. This data can be utilized for diverse purposes within the simulation. Several typical scenarios involve the utilization of:

System Performance Evaluation, Channel Modeling, System Synchronization, BER Testing.

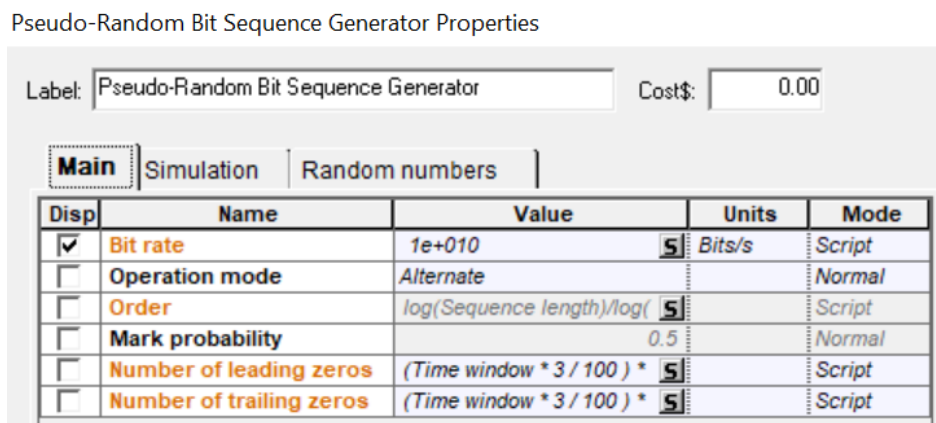

Fig.2 Properties of pseudo-random bit sequence generator

- 2- The CW Laser, the average output Power is important parameter for provide the system by power for transmitting the data. Laser phase noise is modeled using the probability density function.
  - 3- Subsequently, the modulated light pulses are conveyed across the optical fiber, serving as the designated medium for communication. An optical fiber refers to an elongated and slender structure composed of glass or plastic, possessing the ability to transmit data with a large bandwidth over extensive distances while experiencing minimal degradation of the signal[6].
  - 4- At the recipient's terminal, a photodetector is present to transform the optical signal into an electrical signal. The photodetector is responsible for sensing and quantifying the magnitude of the light pulses, subsequently transforming them into a sequence of electrical pulses. Subsequently, the computer or any other digital device undertakes the processing of these electrical pulses with the objective of extracting the primary data[7].

CW Laser Properties

Label:  Cost\$:

**Main** | Polarization | Simulation | Noise | Random numbers

Disp	Name	Value	Units	Mode
<input checked="" type="checkbox"/>	Frequency	193.1	THz	Normal
<input checked="" type="checkbox"/>	Power	5	dBm	Normal
<input type="checkbox"/>	Linewidth	10	MHz	Normal
<input type="checkbox"/>	Initial phase	0	deg	Normal

Fig.3 (CW)laser properties

3-The (NRZ) or Non return to Zero code sign. The purpose of the NRZ pulse generator is to produce a digital waveform wherein the signal maintains a consistent voltage level throughout each bit interval. In the context of NRZ encoding, it is common for a high voltage level to symbolize a certain binary state, such as '1', while a low voltage level is indicative of the opposite binary state, such as '0' [8].

The NRZ pulse generator is commonly used in digital communication systems for transmitting binary data over a communication channel[8]. The fundamental functions and purposes of the system involve the encoding of digital data. Specifically, the NRZ pulse generator is responsible for receiving a binary data stream as input and converting each binary bit into a uniform electric pulse waveform.

NRZ Pulse Generator Properties

Label:  Cost\$:

**Main** | Simulation

Disp	Name	Value	Units	Mode
<input type="checkbox"/>	Rectangle shape	Exponential		Normal
<input type="checkbox"/>	Amplitude	1	a.u.	Normal
<input type="checkbox"/>	Bias	0	a.u.	Normal
<input type="checkbox"/>	Position	0	bit	Normal
<input type="checkbox"/>	Rise time	0.05	bit	Normal
<input type="checkbox"/>	Fall time	0.05	bit	Normal

Fig.4 NRZ Pulse Generator Properties

4-The (MZM) or Mach-Zehnder Modulator:

The optical gadget in question is utilized within communication systems to modulate an optical signal by means of an electrical input. The main function of this device is to convert an electrical signal into an optical signal, hence facilitating the transmission of information via an optical fiber[9]. The MZM device receives an electrical input signal and performs modulation by superimposing it onto an optical carrier

wave. The alteration in the refractive index of a material, resulting in a change in the phase or intensity of an optical signal, is achieved by applying an electric voltage to the modulator.

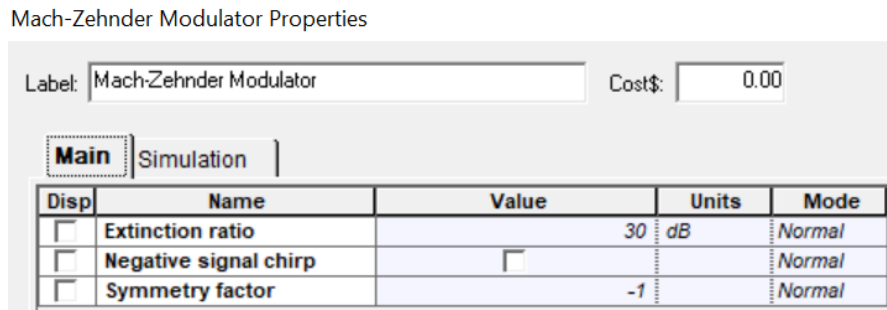

Fig.5 Mach-Zehnder modulator properties

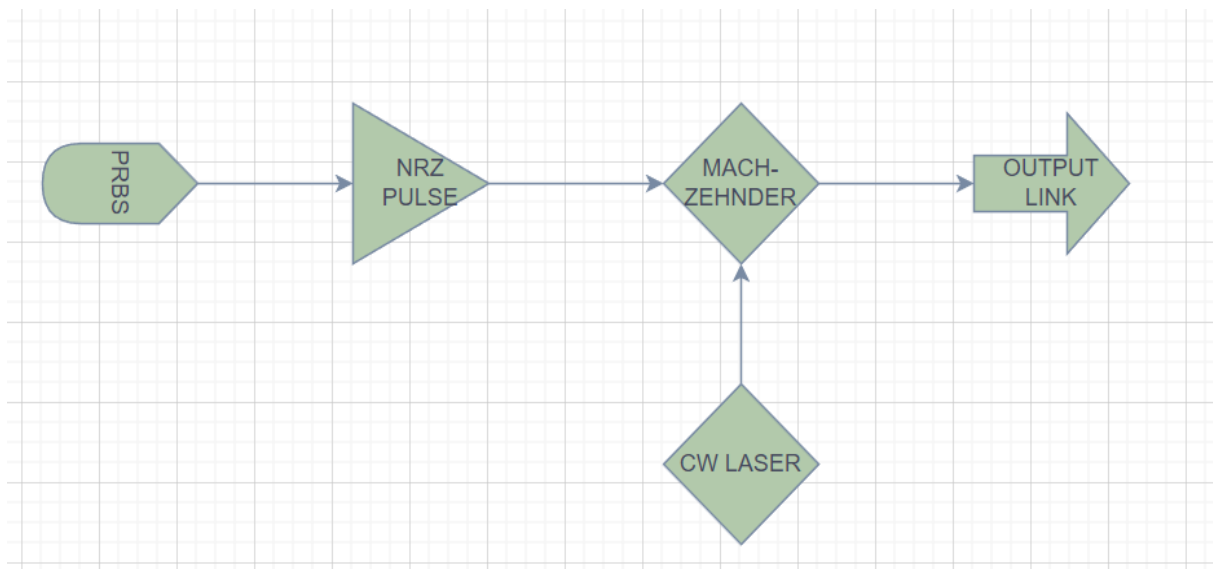

Fig 6 Transmitter circuit

### 3.2 Optical Fiber Circuit

The Optisystem application is a software tool utilized for the simulation and design of optical communication networks. Within this application, fiber optics assumes a critical function in establishing the optical connection between different components included in the simulated system. The role of fiber optics in an optical link inside OptiSystem encompasses the subsequent tasks:

The transmission of optical signals between modified components of the simulated systems is facilitated by the use of fiber optic as the medium. This technology facilitates the transmission of optical signals containing various forms of information, such as data or sound, from the sender to the recipient. The utilization of fiber optic links guarantees the effective and dependable transmission of optical signals while minimizing losses and distortions. The attenuation of this fiber was 0.2db/km.

In OptiSystem, fiber optics facilitates the analysis and evaluation of signal quality parameters, including (SNR) or single to noise ratio[10], (BER) bit error rate[11], and other performance metrics. By modeling the fiber characteristics accurately, OptiSystem allows for the assessment of signal quality and the identification of potential issues or limitations within the optical link.

In this circuit, the type of fiber optic used is single mode (SMF) because of this type is good performance for long distance.

### 3.3 Receiving Circuit

The photodetector, commonly referred to as a photodiode, is a crucial element employed in optical communication systems and various other optical applications. The purpose of its design is to transform incoming optical impulses into matching electrical signals.

Within the framework of OptiSystem, a photodetector is an apparatus designed to replicate the operational characteristics of an actual photodetector within the simulated optical system. The main function of this device is to identify and transform optical signals into electrical currents or voltages, facilitating subsequent processing and analysis of the acquired data.

The key functions and characteristics of a photodetector in OptiSystem include:

Optical Sensitivity, Conversion of Optical Signals, Responsivity, Noise and Nonlinearities.

Photodetector PIN Properties

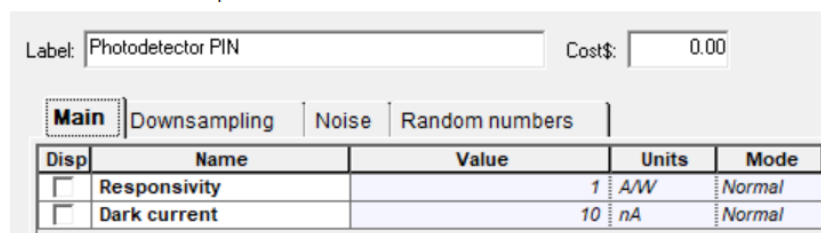

Disp	Name	Value	Units	Mode
<input type="checkbox"/>	Responsivity	1	A/W	Normal
<input type="checkbox"/>	Dark current	10	nA	Normal

Fig.7 Photodetector properties

### 4. Visualize devices

The Visualize devices uses in this simulation was

#### 4.1 Oscilloscope

The oscilloscope visualizer in OptiSystem offers the following functionalities:

Waveform Display, Time-Domain Analysis, Multiple Channel Support.

#### 4.2 Optical spectrum analyzer[12]

The spectrum analyzer in OptiSystem performs the following tasks:

- 1- Frequency Domain Visualization, Spectral Measurements, 3-Signal Analysis and Characterization.

### 5. Practical part

To obtaining the best value of Q. factor and the lowest value of bit error rate or BER, select some of frequencies compared with different lengths for optical fiber cable and the measured frequencies are (1625, 810, 1550) nm As for the lengths used in the optical cable, they started from 60 km to 160 km, with an increase of 20 km in each measurement, and the results were as follows.

When choosing the frequency 1625nm the results was.

Table 1: Q factor and BER in 1625nm wavelength

distance	Q. Factor	BER
60	21.27	$8.5 e^{-25}$
80	10.512	$3.8 e^{-26}$
100	9.13	$2.7 e^{-20}$
120	5.1	$1.25 e^{-7}$
140	3.9	$3.9 e^{-5}$
160	2.13	$-8.8 e^{-5}$

The previously formed parts are connected together, the transmitter circuit is connected with the optical fiber and this fiber is connected with the receiving circuit as shown in the figure below

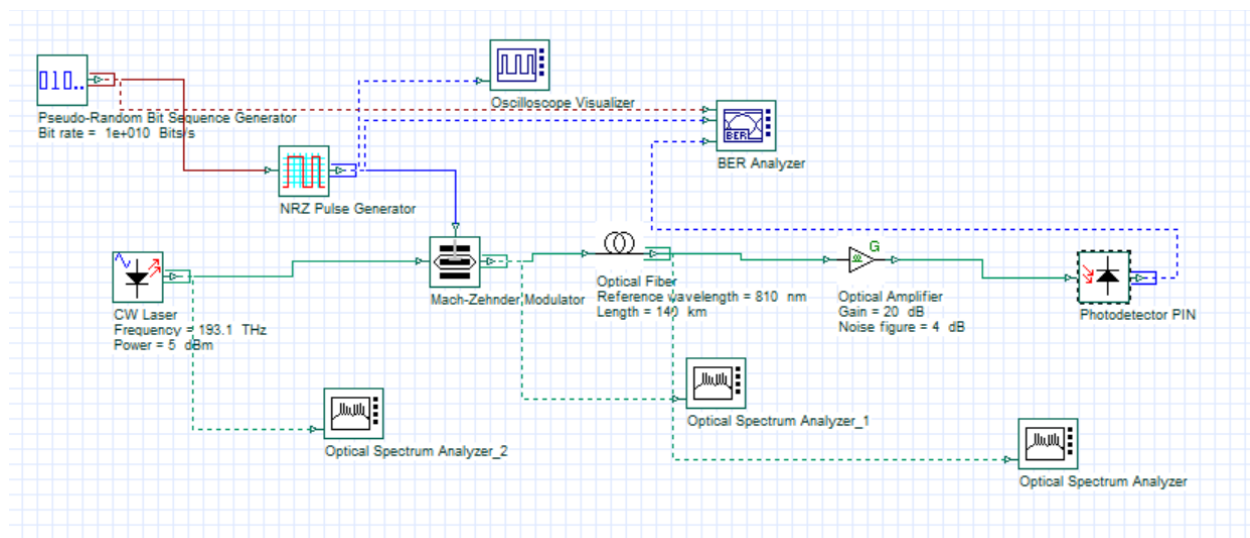

Fig.8 Illustrate the parts of the optisystem used

### 5.1 1625nm wavelength

The initial wavelength employed in the study was 1625 nm, and comprehensive measurements were conducted, encompassing the determination of the Q factor and bit error rate (BER). Additionally, the lengths of the fiber were modified, ranging from 60 km to 140 km, with an increment of 20 km for each subsequent measurement, and the results were as follows

Table 2: 1625nm Distance vs Q.Factor

Distance (Km)	Q. Factor
60	21.27
80	10.512
100	9.13
120	5.1
140	3.9
160	2.13

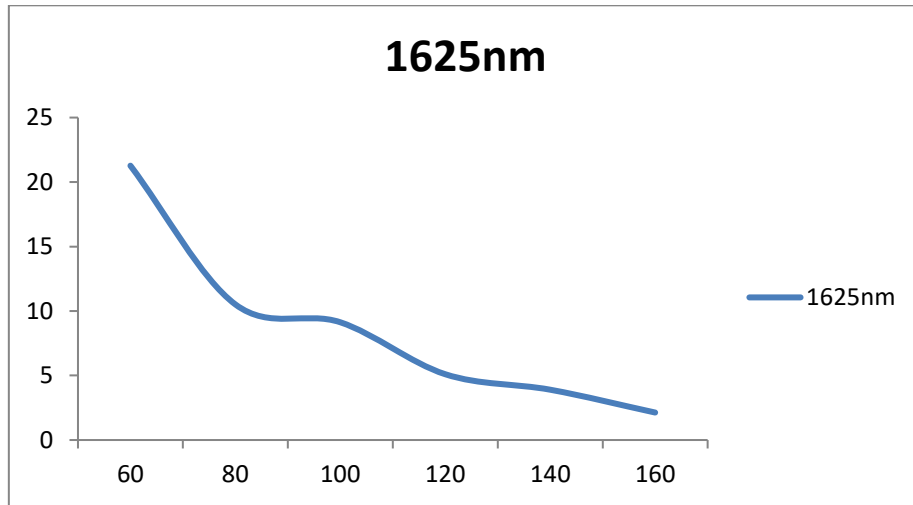
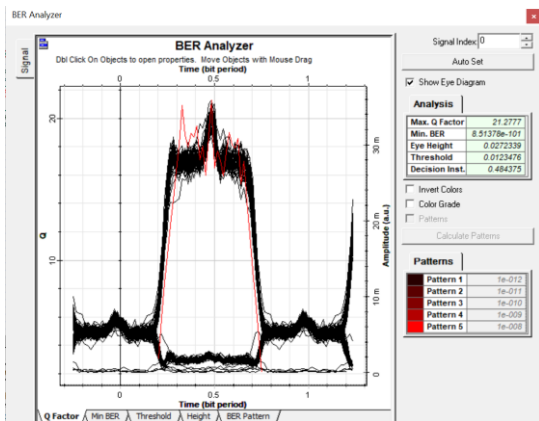
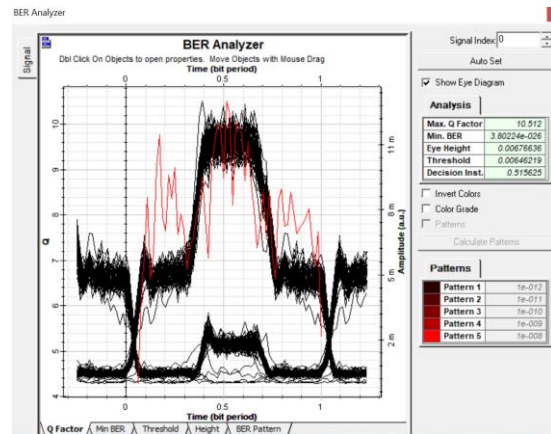

Fig.9 Illustrate Q.factor vs cable length in km for 1625nm wavelength



Eye diagram 1625nm wave length in 60 km cable



Eye diagram 1625nm wave length in 80 km cable

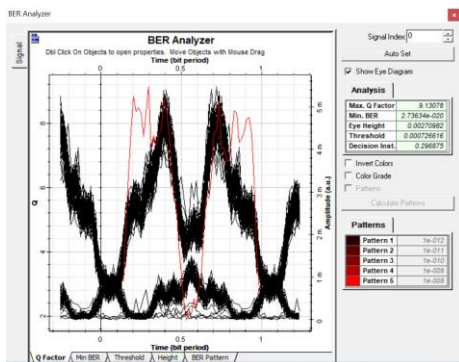

Eye diagram 1625nm wave length in 100 km

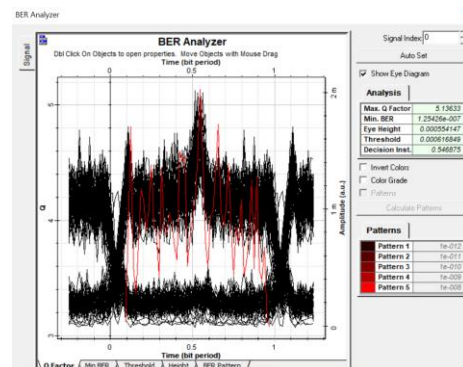

Eye diagram 1625nm wave length in 120 km cable

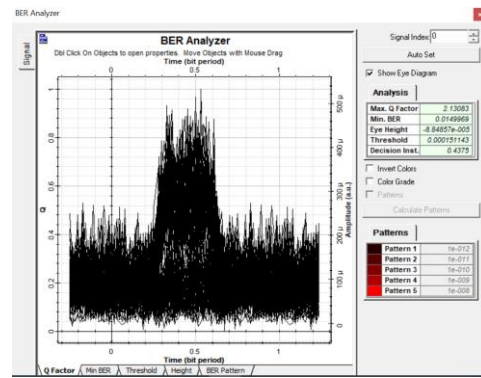
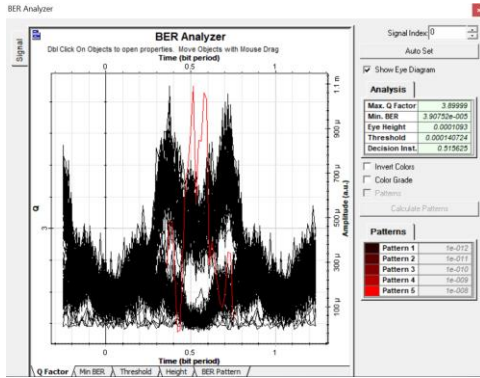

Eye diagram 1625nm wave length in 140 km cable

Eye diagram 1625nm wave length in 160 km

### 5.2 the 1550nm wavelength

The previous measurements used in the wavelength were repeated with the length 1550nm and the results of Q factor and BER were

Table 4: Q factor and BER in 1550nm wavelength

Distance in (Km)	Q Factor	BER
60	10.33	$2.15 e^{-25}$
80	5.09	$1.74 e^{-7}$
100	4.9	$1.98 e^{-6}$
120	2.3	$9.7 e^{-3}$
140	0	1

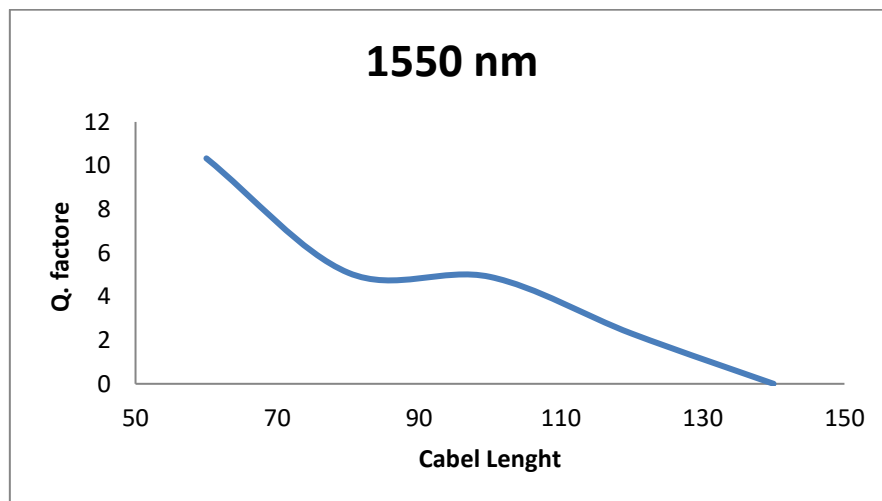
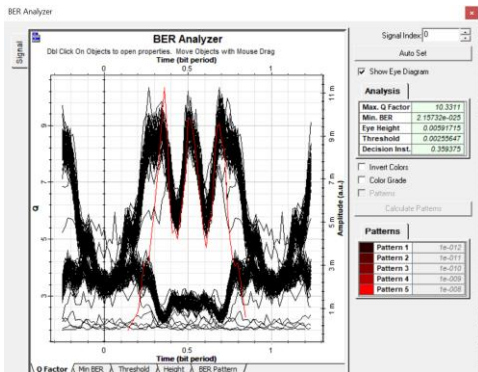
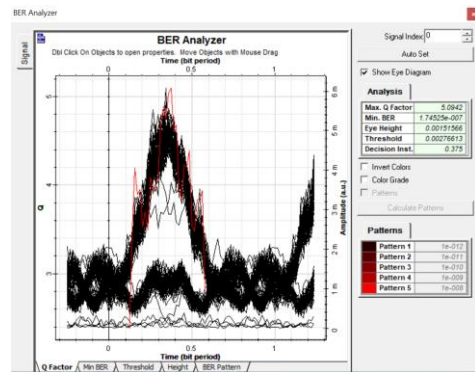

Fig.10 Illustrate Q.factor vs cable length in km for 1550nm wavelength



Eye diagram 1550nm wave length for 80 km cable



Eye diagram 1550nm wave length for 100 km cable

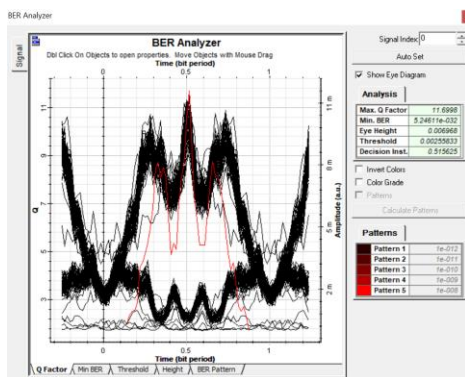

Eye diagram 1550nm wave length for 120 km cable

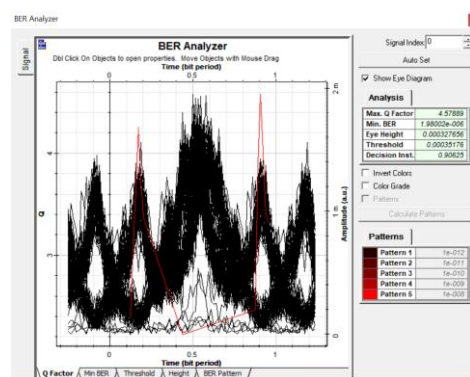

Eye diagram 1550nm wave length for 140 km cable

### 5.3 wave length 810

In order to compare with the previous results, the same steps are repeated with the new wavelength, which is 810

Table 5: Q. factor and BER in 810nm wavelength

Distance (Km)	Q Factor	BER
60	11.17	$5.2 e^{-32}$
80	5.5	$1.3 e^{-8}$
100	4.2	$8.5 e^{-6}$
120	0	1

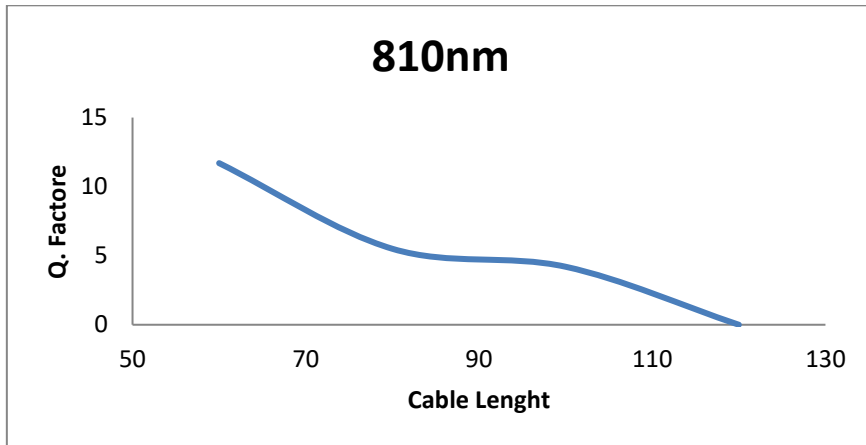
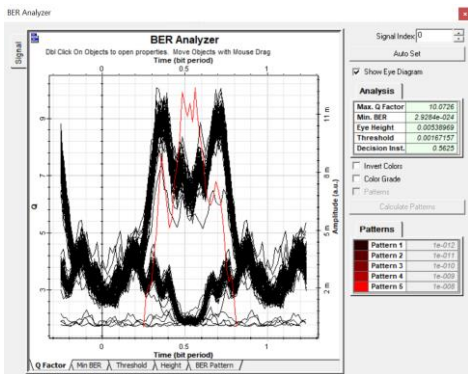
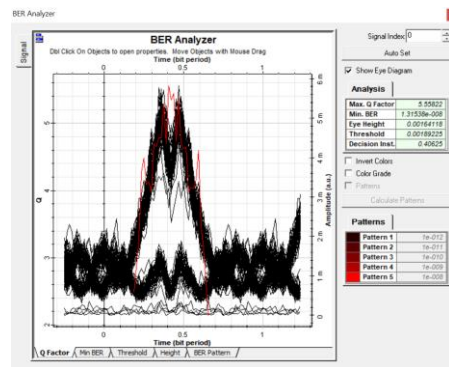

Fig.11 Illustrate Q.factor vs cable length in km for 810nm wavelength



Eye diagram 810nm wave length for 80 km cable



eye diagram 810nm wave length for 100 km

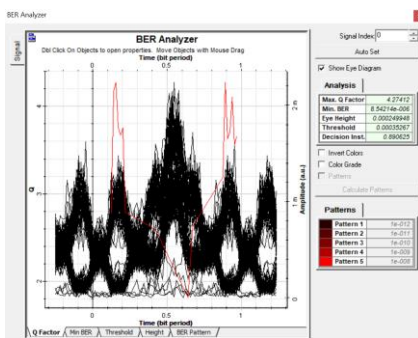

Eye diagram 810nm wave length for 120 km cable

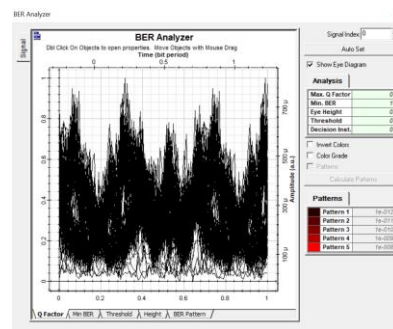

eye diagram 810nm wave length for 140 km

## 6. Conclusion

From the previous tables, the longer the cable length, the lower the Q factor value, and the higher the ber value until it reaches the highest value, which is zero. This indicates that the greater the length, the greater the attenuation and the lower the quality of the signal arriving at the receiver. The best value

for Q-Factor is at the frequency of 1625nm, and after that comes the frequency of 810, and finally the frequency of 1550. For sending a big data over long distances, it is preferable that the frequency used to embed the signal is what we mentioned above.

## Recommendations

Based on the obtained results, it is advisable to employ a wavelength of 1625 nm as the optimal choice for the transmission of data across distances spanning from 60 km to 140 km. The exceptional performance of this technology guarantees dependable and effective transfer of data, facilitating uninterrupted contact across extensive distances. The aforementioned discoveries make a valuable contribution to the enhancement of optical communication systems by aiding in the identification of appropriate wavelengths that align with certain distance criteria.

## Acknowledgments

The author would like to thank Prof. Dr. Mazin A. A. Ali for his advice and guidance in completing the article.

## References

- [1] Uysal, M. and H. Nouri. *Optical wireless communications—An emerging technology*. in *2014 16th international conference on transparent optical networks (ICTON)*. 2014. IEEE.
- [2] Ali, A.H., H.J. Alhamdane, and B.S. Hassen, *Design analysis and performance evaluation of the WDM integration with CO-OFDM system for radio over fiber system*. Indonesian Journal of Electrical Engineering and Computer Science, 2019. **15**(2): p. 870-878.
- [3] Awalia, W. and A. Pantjawati. *Performance simulation of fiber to the home (FTTH) devices based on optisystem*. in *IOP Conference Series: Materials Science and Engineering*. 2018. IOP Publishing.
- [4] Othman, M., et al., *An analysis of 10 Gbits/s optical transmission system using fiber Bragg grating (FBG)*. IOSR Journal of Engineering (IOSRJEN) ISSN, 2012: p. 2250-3021.
- [5] Rahman, S., et al., *Mitigation of nonlinear distortions for a 100 Gb/s radio-over-fiber-based WDM network*. Electronics, 2020. **9**(11): p. 1796.
- [6] Sobolewski, J.S., *Fiber optics*, in *Encyclopedia of Computer Science*. 2003. p. 702-704.
- [7] Chacon, P.J., et al., *A wearable pulse oximeter with wireless communication and motion artifact tailoring for continuous use*. IEEE Transactions on Biomedical Engineering, 2018. **66**(6): p. 1505-1513.
- [8] Omer, E., *Performance of optical fiber communication system*. 2022.
- [9] Haffner, C., et al., *All-plasmonic Mach-Zehnder modulator enabling optical high-speed communication at the microscale*. Nature Photonics, 2015. **9**(8): p. 525-528.
- [10] Johnson, D.H., *Signal-to-noise ratio*. Scholarpedia, 2006. **1**(12): p. 2088.
- [11] Ali, I., *Bit-error-rate (BER) simulation using MATLAB*. International Journal of Engineering Research and Applications, 2013. **3**(1): p. 706-711.
- [12] Wagener, J.L., et al. *Fiber grating optical spectrum analyzer tap*. in *Integrated Optics and Optical Fibre Communications, 11th International Conference on, and 23rd European Conference on Optical Communications (Conf. Publ. No.: 448)*. 1997. IET.